

IMPORTANT NOTE:

- Please keep all hardware parts out of the reach of children.
- Two or more people are needed for assembly.

WINNERS ONLY®

ASSEMBLY INSTRUCTIONS

PROD. NO: DV24272

Thank you for purchasing this quality product. Be sure to check all packaging materials carefully for small parts that may have come loose inside the carton during shipment.

CAUTION : Please read instructions thoroughly before unpacking assembly parts. Sharp, exposed staple tips can cause injury, therefore, for your protection, please remove any exposed staples used in packing.

1. We recommend that you should assemble this product with assistance of another person, this will make assembly easier, and will help to eliminate damage to the product or injury to persons during assembly.
2. Be sure to check all packing material carefully for small parts that may be come loose inside the carton during shipment.
3. Please do not over tighten screws or bolts.
4. Please put all the parts on a non- abrasive floor before assembly and follow the assembly steps to assemble your newly purchased product correctly and efficiently.

Reminders :

1. Use only the hardware supplied.
2. This item may require periodic tightening.

COMPONENTS LIST DK24272T			
NO.	DESCRIPTION	SKETCH	QTY
A	Table Top		1 PC
C	Mounting Plate		1 PC
D	Mounting Block		2 PCS
E	Wood Stretcher		2 PCS

COMPONENTS LIST DK24272B			
NO.	DESCRIPTION	SKETCH	QTY
B	Table Leg Frame		2 PCS
F	Hardware Bag		1 PC
G	Levelers		4 PCS

HARDWARE LIST

NO.	DESCRIPTION	SIZE	SKETCH	QTY
1	Short JCBC BOLT with large washers	M6X35mm		14 PCS
2	Short JCBC BOLT with small washers	M6X40mm		4 PCS
3	Long JCBC BOLT with large washers	M6X60mm		2 PCS
4	Flat Washer	Ø 13mm		2 PCS
5	Spring Washer	Ø 18mm		2 PCS
6	Allen Key			1 PC
7	Hex Nut	Ø 13mm		2 PCS
8	Wrench			1 PC

STEP 1

Place Table Top (A) upside down on a soft protective surface such as a carpet. Align & fasten Mounting Block (D) to Table Top (A) using Short JCBC bolt with small washers (2) and fully tighten with Allen Key (6).

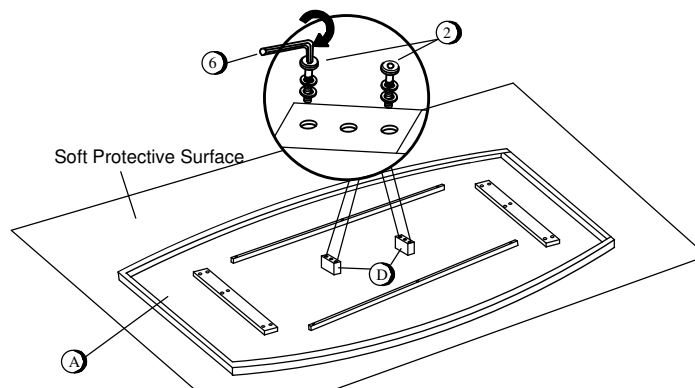
**STEP 2**

Align & fasten Mounting Plate (C) to Mounting Block (D) using Short JCBC bolt with large washers (1) and fully tighten with Allen Key (6).

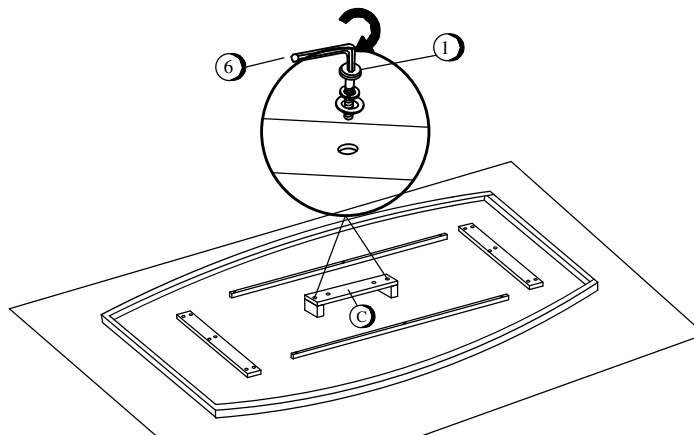

WINNERS ONLY[®]

ASSEMBLY INSTRUCTIONS

PROD. NO: DV24272

STEP 3

Align & fasten Table Leg Frame (B) to Table Top (A) using Short JCBC bolt with large washers (1) and fully tighten with Allen Key (6).

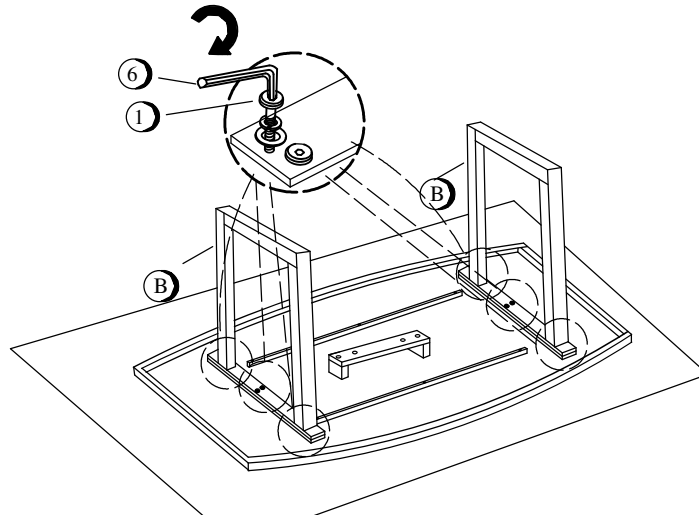

STEP 4

Attach Wood Stretcher (E) to Mounting Plate (C) using Flat Washer (4), Spring Washer (5), Hex Nut (7) and fully tighten with Wrench (8).

Attach Wood Stretcher (E) to Table Leg Frame (B) using Long JCBC Bolt with large washers (3) and fully tighten with Allen Key (6).

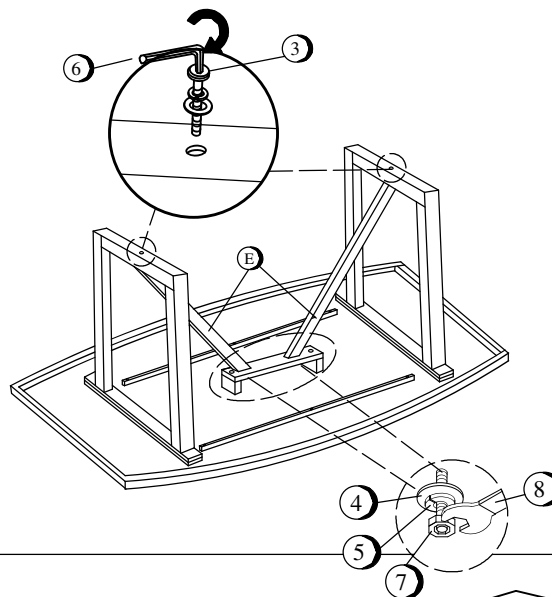

STEP 5

Turn the table to upright position.

Assembly is now complete.

Thank you for purchasing this product.

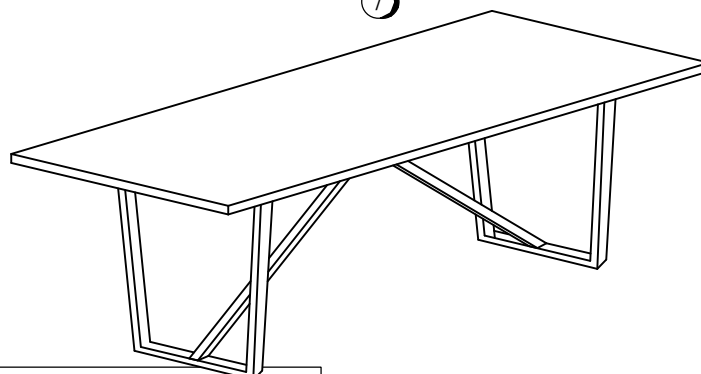

CARE INSTRUCTION

- ~ Be sure to use the same type of polish consistently.
- ~ Your furniture will appear cloudy or streaky if oil based or wax are interchanged.
- ~ Spray your furniture surface evenly. Wipe in a circular motion with a soft clean cloth.