





WINNERS ONLY® Assembly Instructions

DQT145224E / DST45224E / DCT35224G / DCT35224R / DBT52224 / DPT52224
RAKE BACK BARSTOOL

Caution: Please read instruction thoroughly before unpacking assembly parts. Sharp exposed staple tips can cause injury, therefore, for your protection, please remove any exposed staples used in packing. Please keep all hardware parts out of reach of children.

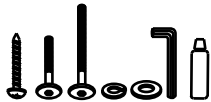
1. We recommend that you should assemble this product with the assistance of another person; this will make assembly easier, and will help to eliminate damage to the product or injury to persons during assembly.
2. Be sure to check all packing materials carefully for small parts that may have come loose inside the carton during shipment.
3. Please do not over tighten screws or bolts. Reminder
 1. use only the hardware supplied.
 2. Do not over-tighten the bolts.
 3. This item may require periodic tightening.

PARTS LIST

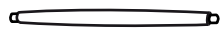
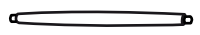
PART NO	FIGURE	DESCRIPTION	Q'TY
DQT145224E-01 / DST45224E-01 / DCT35224G-01		Hardware Bag	1 Pce
DQT145224E-02 / DST45224E-02 / DCT35224G-02		Chair Back	1 Pce
DQT145224E-03 / DST45224E-03 / DCT35224G-03		Wood Seat With Frame	1 Pce
DQT145224E-05 / DST45224E-05 / DCT35224G-05		Front Leg (Right)	1 Pce
DQT145224E-06 / DST45224E-06 / DCT35224G-06		Front Leg (Left)	1 Pce
DQT145224E-07 / DST45224E-07 / DCT35224G-07		Side Stretcher (Right / Left)	2 Pcs
DQT145224E-10 / DST45224E-10 / DCT35224G-10		Front Stretcher (Short)	1 Pce

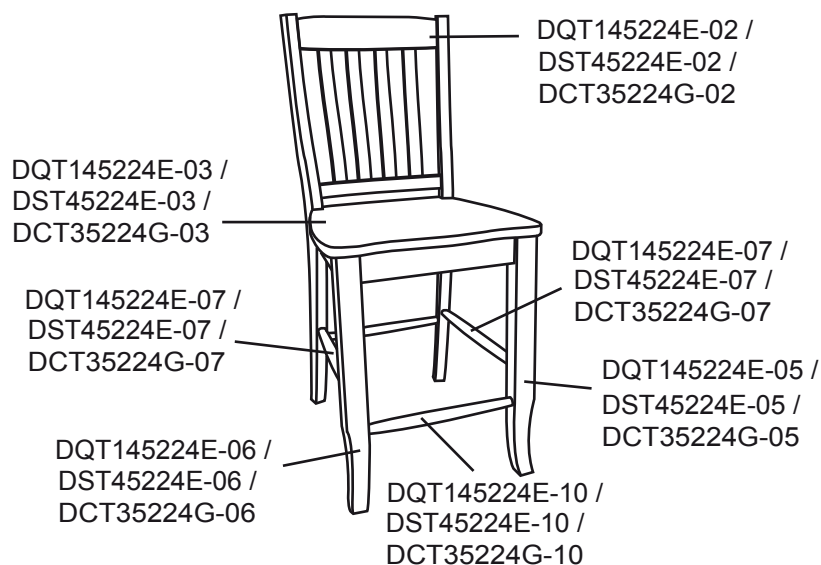







WINNERS ONLY® Assembly Instructions

DQT145224E / DST45224E / DCT35224G / DCT35224R / DBT52224 / DPT52224

RAKE BACK BARSTOOL

HARDWARE PARTS :

						
8x1.1/4" Pan Head Screw 6 pcs	M6x40mm JCBC Bolt 2 pcs	M6x70mm JCBC Bolt 8 pcs	M6x13mm Lock Washer 10 pcs	M6.5x16.5mm Flat Washer 10 pcs	Allen Key 1 pce	Glue 1 pce

ASSEMBLY:

1. Attach the Wood Seat with Frame to the Chair Back using the provided hardware as shown in Fig 1.
2. Attach side Stretcher (Left/Right) to Chair back using the provided hardware as shown in Fig 2.2.
Attach Front Stretcher to front legs using the provided hardware as shown in Fig.2.
Attach Front legs (Left/Right) to Wood Seat with Frame using the provided hardware as shown in Fig2.1.

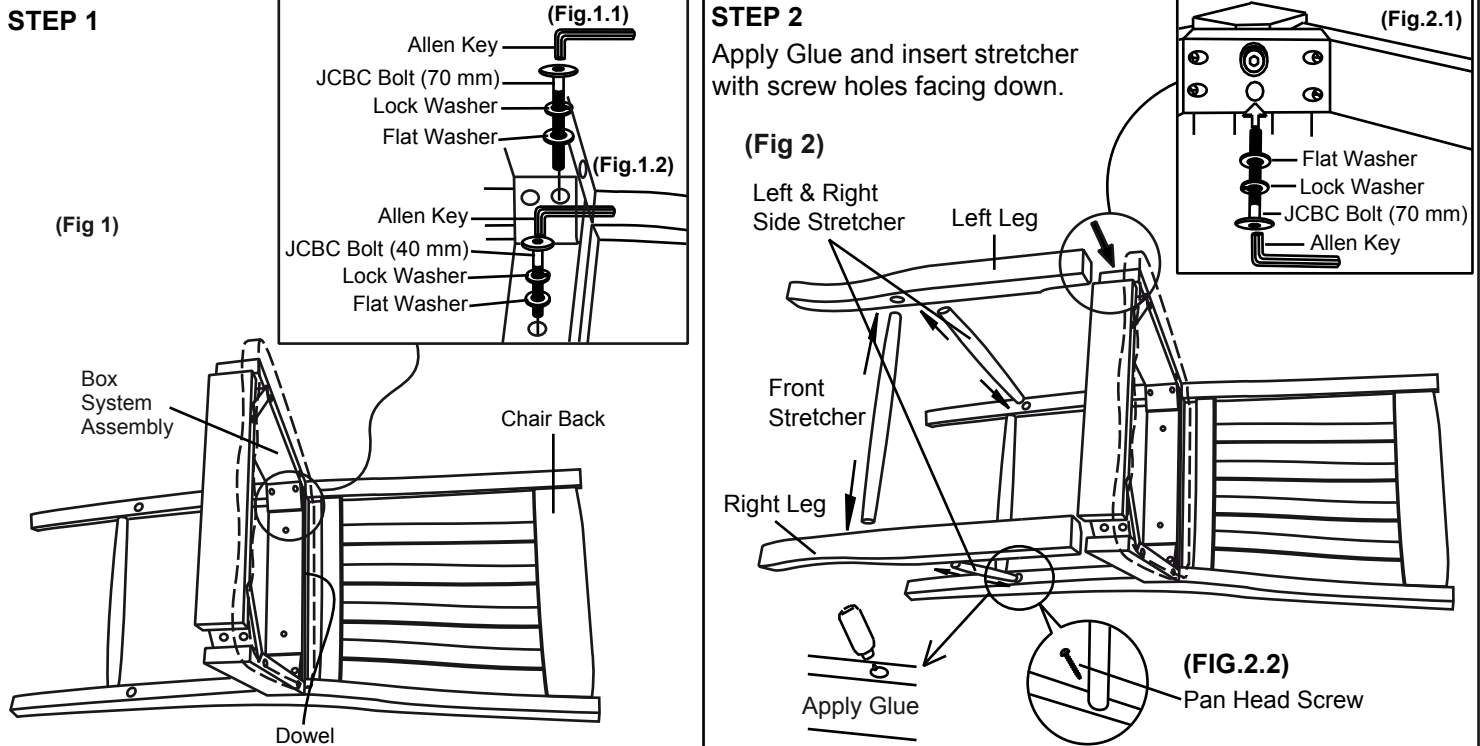

STEP 3

Turn the chair upright. Check its balance and tighten all screws and bolts to complete the assembly.

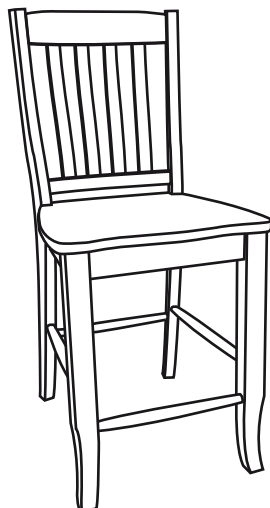

IMPORTANT NOTE :

~ Please keep all hardware out of the reach of children.

CARE INSTRUCTION

- ~ Be sure to use the same type of polish consistently. Your furniture will appear cloudy or streaky if oil based or wax based polishes are interchanged.
- ~ Spray your furniture surface evenly. Wipe in a circular motion with a soft clean cloth.