

Assembly Instructions

DFLT / DFDT45124 / DFWT145124

BARSTOOL-L

PARTS LIST

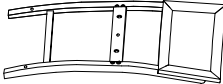
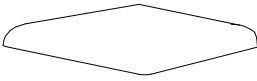
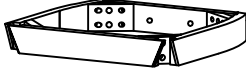
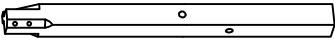
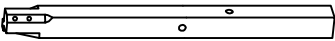
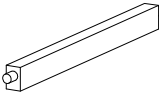
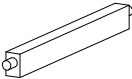

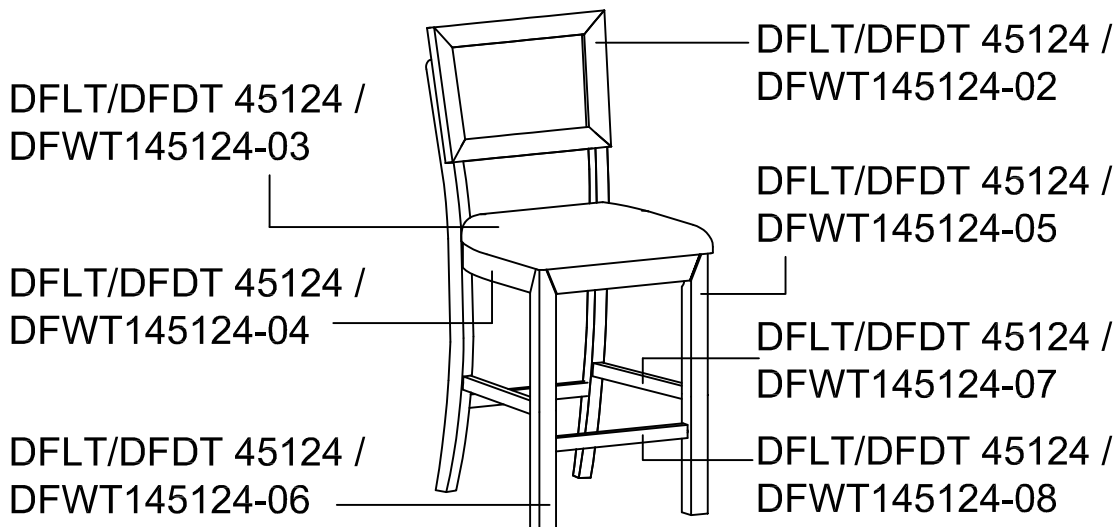

| PART NO | FIGURE | DESCRIPTION | Q'TY |
|------------------------------------|---|-------------------|-------|
| DFLT/DFDT 45124 / DFWT145124-01 |  | Hardware Bag | 1 Pc |
| DFLT/DFDT 45124 / DFWT145124-02 |  | Chair Back | 1 Pc |
| DFLT/DFDT 45124 / DFWT145124-03 |  | Cushion Seat | 1 Pc |
| DFLT/DFDT 45124 / DFWT145124-04 |  | Seat Frame | 1 Pc |
| DFLT/DFDT 45124 / DFWT145124-05 |  | Front Leg (Right) | 1 Pc |
| DFLT/DFDT 45124 / DFWT145124-06 |  | Front Leg (Left) | 1 Pc |
| DFLT/DFDT 45124 / DFWT145124-07 |  | Side Stretcher | 2 Pcs |
| DFLT/DFDT 45124 / DFWT145124-08 |  | Front Stretcher | 1 Pc |



Assembly Instructions

DFLT / DFDT45124 / DFWT145124
BARSTOOL-L

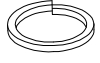
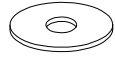
HARDWARE PARTS :

| | | | | | | |
|---|---|---|---|---|--|---|
|  |  |  |  |  |  |  |
| JCBC Bolt 80mm 4 pcs | JCBC Bolt 50mm 4 pcs | JCBC Bolt 40mm 2 pcs | Lock Washer 10 pcs | Flat Washer 10 pcs | Wood Screw 6 pcs | Allen Key 1 pc |

ASSEMBLY:

1. Position the Chair Back on a soft surface such a carpet. Place the Box System Assembly(Wood seat is pre-attached to the seat frame in assembly) on to the middle rail of the Chair Back with the dowel fully inserted into the pre-drilled hole.
 - 1.1 Insert 80mm JCBC Bolt through a Lock Washer and a Flat Washer through the rear pre-drilled holes on the rear Corner Block of the seat frame.
 - 1.2 Insert the 40mm JCBC Bolt through a Lock Washer and a Flat Washer through the rear pre-drilled holes on the seat frame.
2. Insert each Side Stretcher into pre-drilled holes on both of the Rear Legs, make sure that screw holes on the Stretcher are facing down. Place the Front Leg to Corner Block of the frame, then insert Side Stretcher and Front Stretcher into the Legs.
 - 2.1 Insert the 50mm JCBC Bolt through a Lock Washer and a Flat Washer and the pre-drilled holes of Corner Block into the pre-drilled holes on the Front Leg by using the provided Allen Key. But do not fully tighten the bolts yet.
 - 2.2 Insert Wood Screw into Side Stretcher through the pre-drilled holes, tighten with Screw-Driver (not included)

STEP 1

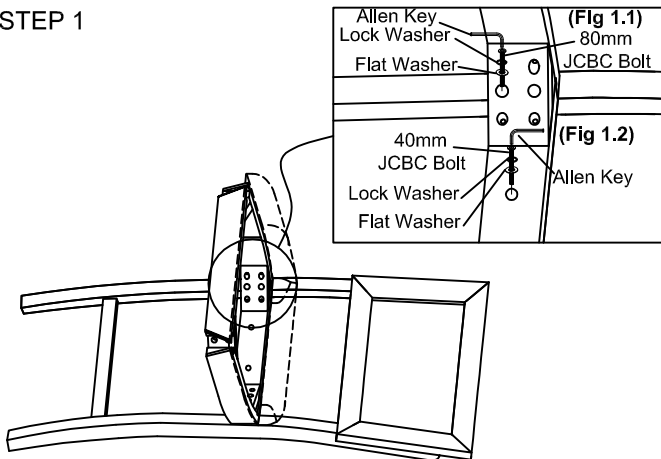

STEP 2

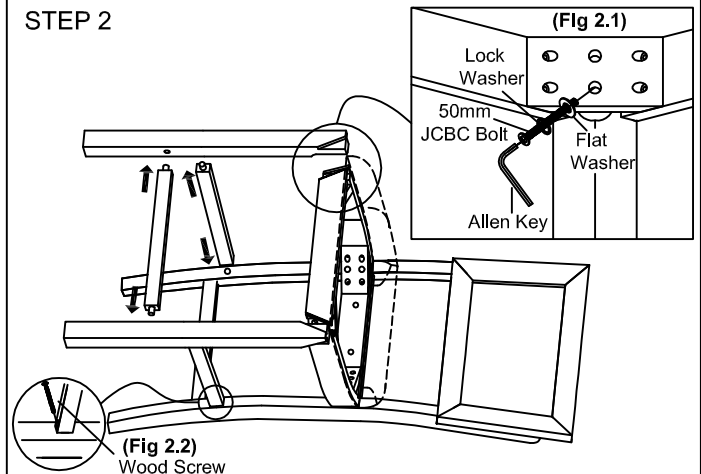

STEP 3

Turn the chair to standing position. Check it's balance and tighten all screw and bolt to complete the assembly.



CARE INSTRUCTION

- Be sure to use the same type of polish consistently. Your furniture will appear cloudy or streaky if oil based or wax based polishes are interchanged.
- Spray your furniture surface eventit. Wipe in a circular motion with a soft clean cloth.