

WINNERS ONLY®

ASSEMBLY INSTRUCTIONS

PROD. NO : DE1452SLG

DE1452SEP/DW3452S

DE1452SLP





DE1452SEG

Thank you for purchasing this quality product . Be sure to check all packaging material carefully for small parts that may have come loose inside the carton during shipment .



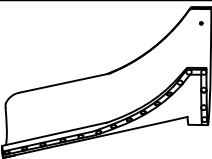
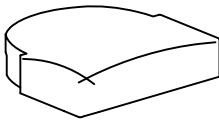



"Hardware is attached underneath the CUSHION SEAT"

This product will take 15-20 minutes to assemble.

Components List :

NO	DESCRIPTION	SKETCH	QTY
A	Back Rest		1pc
B	Seat Frame		1pc
C	Front Legs		2pcs
D	Back Legs		2pcs
E	Velcro		1pc
F	Plastic Glide		4pcs

Hardware List :

NO	DESCRIPTION	SIZE	SKETCH	QTY
1	Short Bolt	5/16" x38 mm		4pcs
2	Long Bolt	5/16" x57 mm		4pcs
3	Middle Bolt	5/16" x45 mm		4pcs
4	Spring Washer	5/16" x Ø12		12pcs
5	Flat Washer	5/16" x Ø19		12pcs
6	Allen Key	58x23x4 mm		1pc

Hammer may be require for assembly
Not included

Reminders

1. Use only the hardware supplied.
2. Once the chair is finished, level and tighten all the bolts.
3. Do not over-tighten bolts.
4. This item may require periodic tightening.

NOTE : Hardware Bag is located underneath the cushion seat (B)

NOTE :

1. Hardware pack is located underneath the Cushion Seat (B)
2. Two or more people are needed for assembly, Please keep all hardware parts out of the reach of children.

WINNERS ONLY® ASSEMBLY INSTRUCTIONS

PROD. NO : DE1452SLG
DE1452SEP/DW3452S
DE1452SLP
DE1452SEG

Grab Hardware Bag from underneath the Cushion Seat.
Do not fully tighten bolts until the product is level and the assembly of the product is completed.

Fig. 1

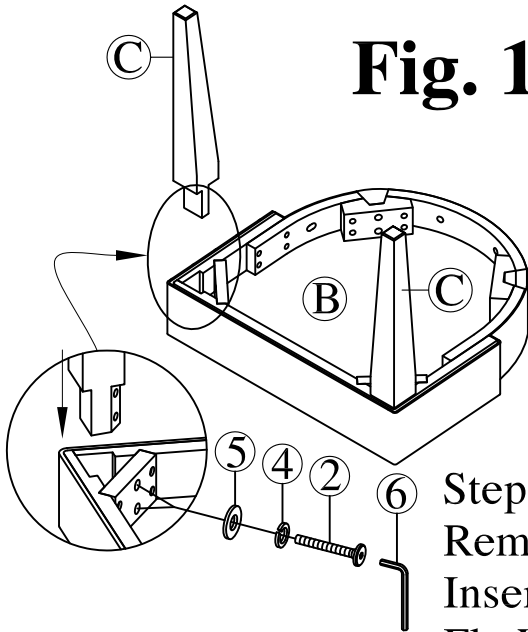

Step 1.

Remove Velcro from underneath the Cushion Seat (B)
Insert Front Legs (C) to Cushion Seat (B) by using
FlatWasher (5), SpringWasher (4), Long Bolt (2)
and tighten with Allen Key (6) as shown in Fig. 1

Do not fully tighten bolts

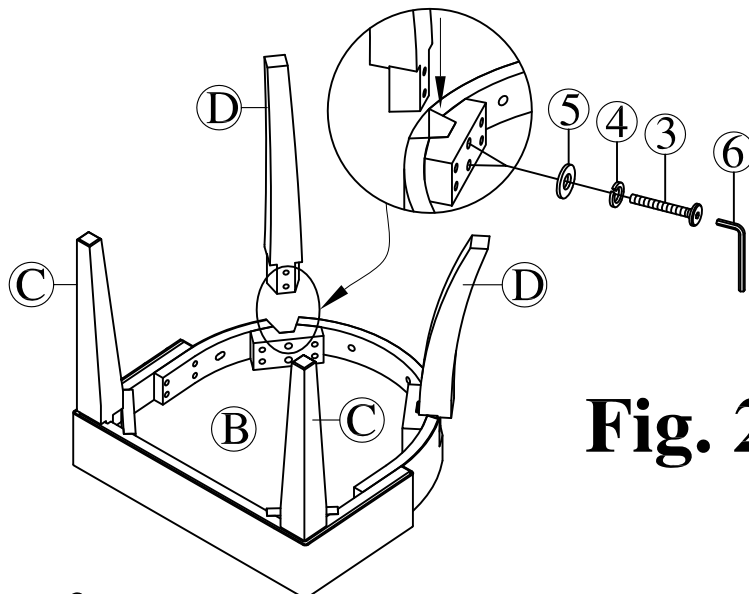

Fig. 2

Step 2.

Attach Back Leg (D) to Cushion Seat (B) by using
Short Bolt (1), FlatWasher (5), SpringWasher (4)
and tighten with Allen Key (6) as shown in Fig. 2.

Do not fully tighten bolts

WINNERS ONLY® ASSEMBLY INSTRUCTIONS

PROD. NO : DE1452SLG
DE1452SEP/DW3452S
DE1452SLP
DE1452SEG

Fig. 3

Note: Apply pressure to the Seat Cushion in order to bring the Seat Cushion and Backrest together.

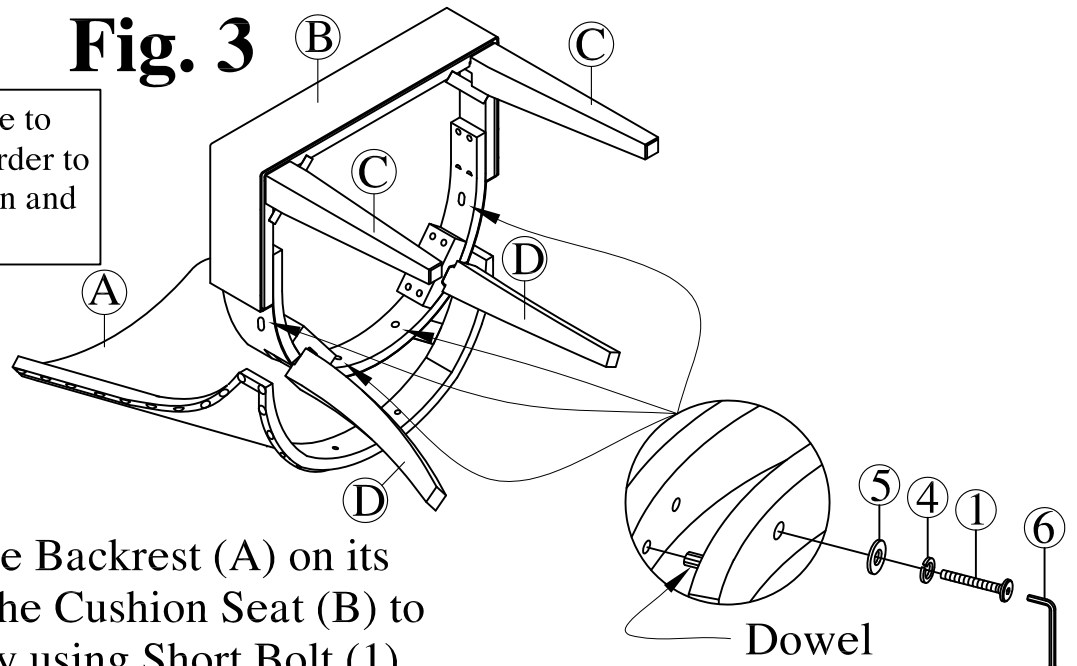

Step. 3 : Lay the Backrest (A) on its back and attach the Cushion Seat (B) to Back Rest (A) by using Short Bolt (1), FlatWasher (5), SpringWasher (4) and tighten with Allen Key (6) as shown in Fig. 3.

Fig. 4

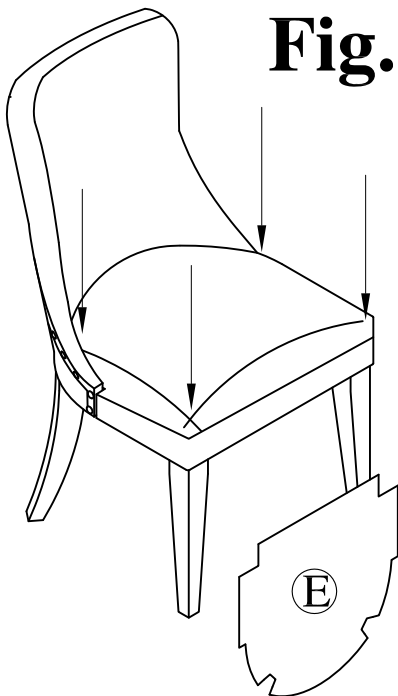

Step 4: Place the loosely assembled chair on a hardflat surface and apply gentle downward pressure on the seat.as shown on Fig.4. Once the chair is balanced and leveled,fully tighten all bolts an attach velcro (E) to cushion seat (B).

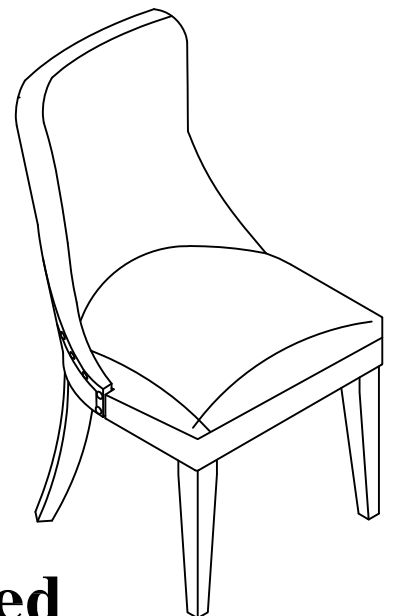

Step 5:Once all the bolts have been tightened attach Velcro (E) to underneath the Cushion Seat (B) as shown in Fig. 4.

Assembly is now completed