

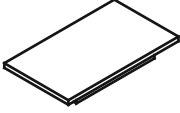

WINNERS ONLY® Assembly Instructions



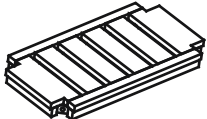

AC101E / AE201E / AR201E 14" CHAIR SIDE TABLE

Thank you for purchasing this quality product. Be sure to check all packaging material carefully for small parts that may have come loose inside the carton during shipment.

COMPONENT LIST:

PART NO	FIGURE	DESCRIPTION	QTY
AC101E-01		Hardware Bag	1 pce
AC101E-13		Table Top	1 pce
AC101E-07		Legs	4 pcs
AC101E-22		Fixed Shelf	1 pce

HARDWARE LIST:

PART NO	FIGURE	DESCRIPTION	QTY
1		JCBC Bolt (Long)	8 pcs
2		JCBC Bolt (Short)	4 pcs
3		Lock Washer	12 pcs
4		Flat Washer	12 pcs
5		Allen Key	1 pce

This product will take 15-20 minutes to assemble.

Reminders

1. Use only the hardware supplied.
2. Once the product is assembled, level and tighten all the bolts.
3. Do not over-tighten bolts.
4. This item may require periodic tightening

NOTE:

1. Two or two people are needed for assembly
2. Please keep all hardware parts out of the reach of children.

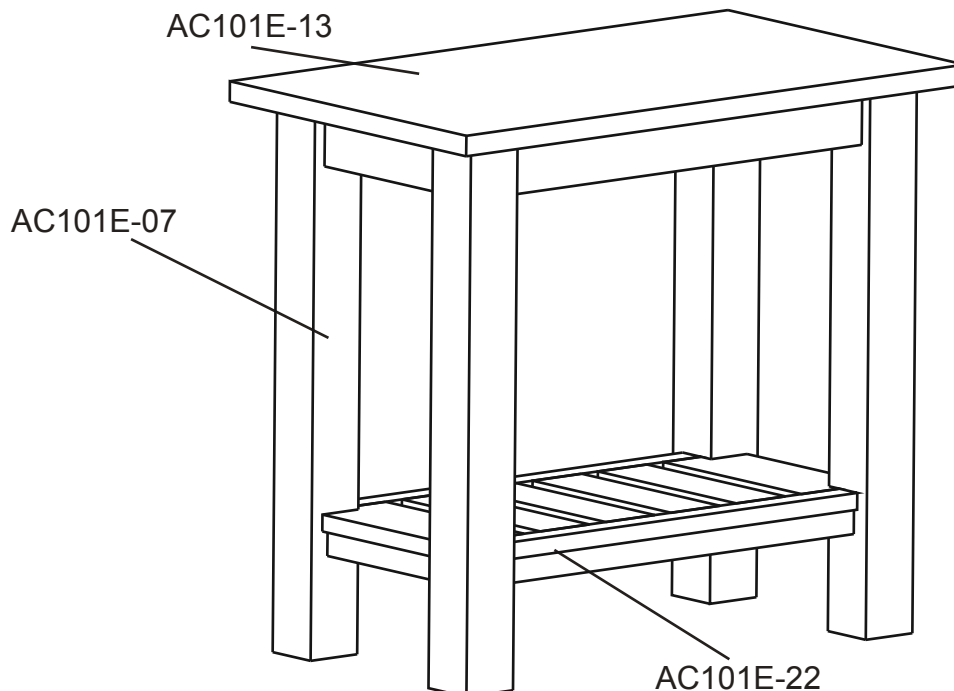

WINNERS ONLY[®] Assembly Instructions

AC101E / AE201E / AR201E
14" CHAIR SIDE TABLE

ASSEMBLY :

STEP 1

- 1.1-Turn the Table Top upside down on a protective surface such as carpet or other soft material.
- 1.2- insert the three legs into the corner of the apron by insert the **Flat Washer(4)**,**Lock Washer(3)** and **JCBC Bolt(1)** into pre-drilled holes on the corner block and tighten it using **Allen key(5)**.
- 1.3-Insert the Fixed Shelf into the leg assembly, then install the fourth leg using **Flat Washer(4)**, **Lock Washer(3)** and **JCBC Bolt(1)** into the pre-drilled holes on the corner block and tighten using **Allen key(5)**.
- 1.4- Insert the **Flat Washer(4)**, **Lock Washer(3)** and **JCBC Bolt(2)** into pre-drilled holes on the corner block of Fixed Shelf and tighten using **Allen key(5)**.

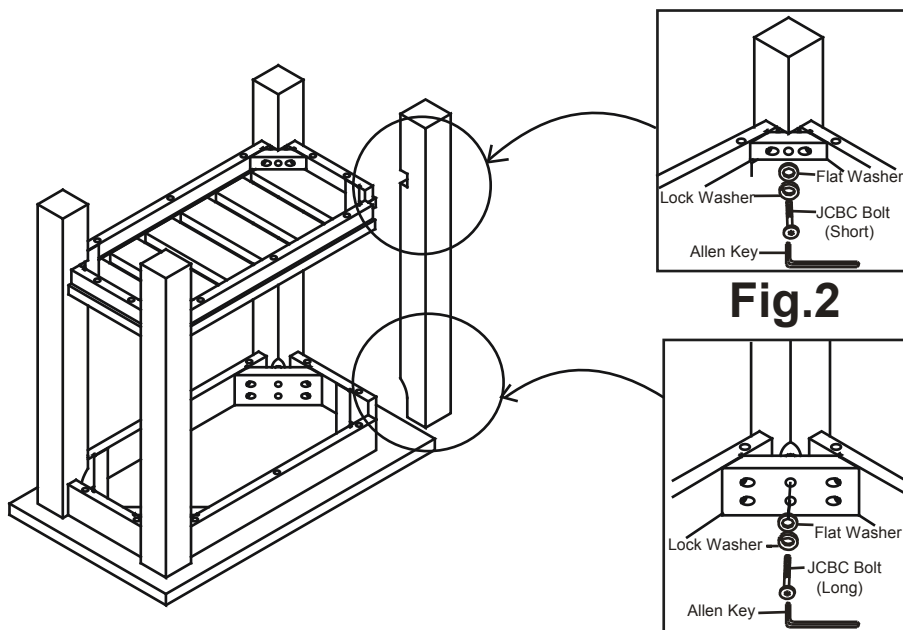

Fig.2

Fig.1

STEP 2

- 3.1- Turn table to upright position.
- 3.2- Once lamp table is fully balance fully tighten all bolts.

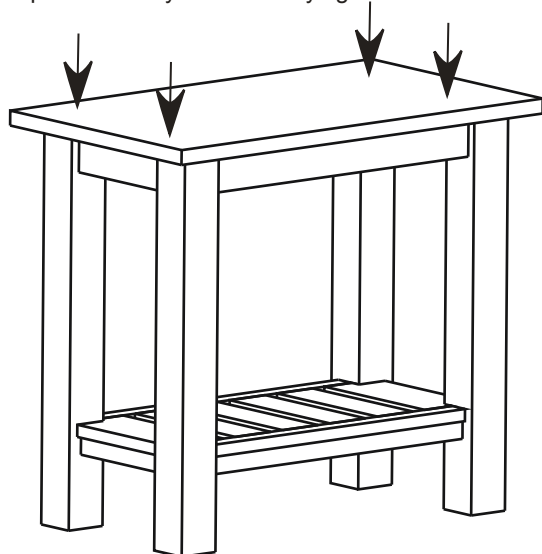

Fig.3

Assembly is now Completed.

CARE INSTRUCTION

- ~ Be sure to use the same type of polish consistently. Your furniture will appear cloudy or streaky if oil based or wax based polishes are interchanged.
- ~ Spray your furniture surface evenly. Wipe in a circular motion with a soft clean cloth.