



# WINNERS ONLY® Assembly Instructions

AB100E / APR100E



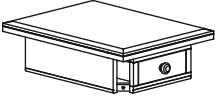

18" END TABLE

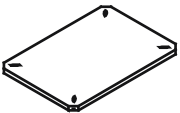
Thank you for purchasing this quality product. Be sure to check all packaging material carefully for small parts that may have come loose inside the carton during shipment.

## COMPONENT LIST:

PART NO	FIGURE	DESCRIPTION	QTY
AB100E-01		Hardware Bag	1 pce
AB100E-13		Table Top	1 pce
AB100E-07		Legs	4 pcs
AB100E-22		Fixed Shelf	1 pce

## HARDWARE LIST:

PART NO	FIGURE	DESCRIPTION	QTY
1		Hex Bolt	8 pcs
2		Pan Head Screw	4 pcs
3		Lock Washer	8 pcs
4		Flat Washer	8 pcs
5		Wrench	1 pce

This product will take 15-20 minutes to assemble.

### Reminders

1. Use only the hardware supplied.
2. Once the product is assembled, level and tighten all the bolts.
3. Do not over-tighten bolts.
4. This item may require periodic tightening

### NOTE:

1. Two or two people are needed for assembly
2. please keep all hardware parts out of the reach of children.

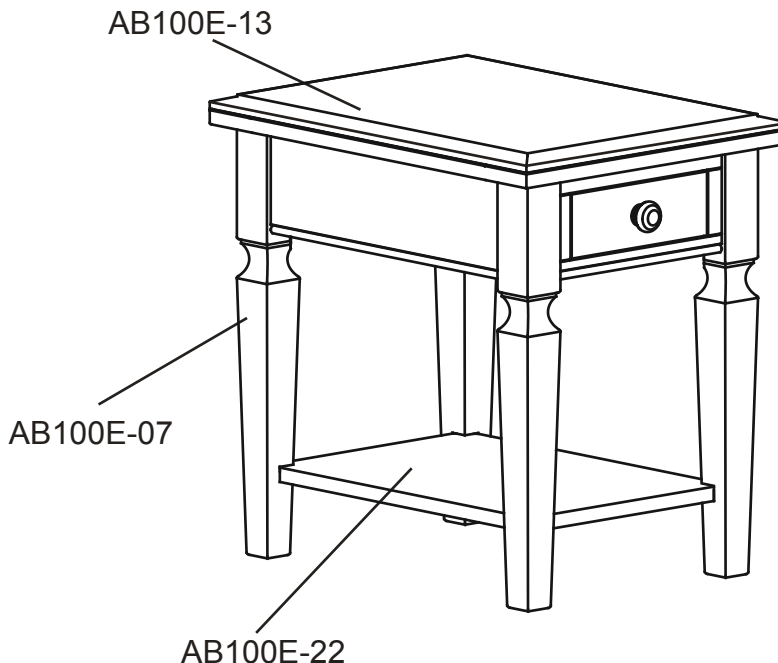

# WINNERS ONLY Assembly Instructions

AB100E / APR100E  
18" END TABLE

## ASSEMBLY :

### STEP 1

- 1.1-Pull out the Drawer Box as shown and Turn the Table Top upside down on a protective surface such as carpet or other soft materials as shown in the Fig1.
- 1.2-Use **Flat Washer(4)**, **Lock Washer(3)**, **Hex Bolt(1)** and **Wrench(5)**, to attach three legs randomly to the table top, do not fully tighten yet.
- 1.3-Insert the fixed shelf into the legs as shown in the Fig1.

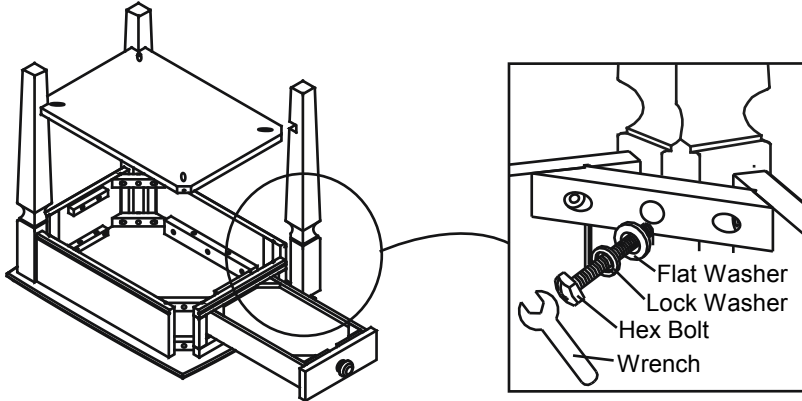

Fig.1

### STEP 2

- 2.1-Insert the last leg to the corner of apron frame and Fixed Shelf. Then tighten with **Flat Washer(4)**, **Lock Washer(3)** and **Hex Bolt(1)** using the **Wrench(5)** provided.
- 2.2- Insert and tighten the **Pan Head Screw(2)** using a screw-driver (Not provided) into the Fixed Shelf to secure Shelf as shown on Fig.2

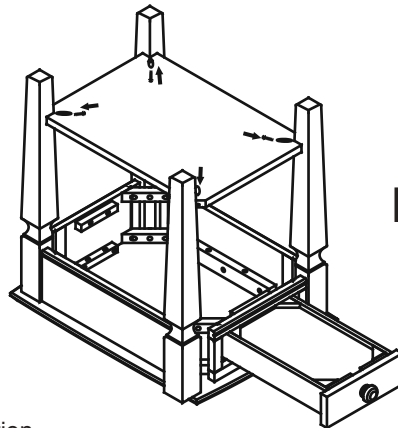

Fig.2

### STEP 3

- 3.1- Turn table to upright position.
- 3.2- Once end table is fully balance fully tighten all bolts.

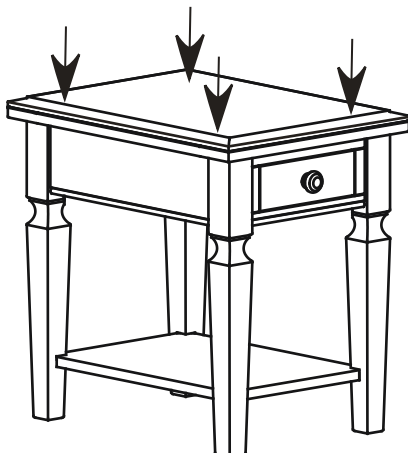

Fig.3

Assembly is now Completed.

#### CARE INSTRUCTION

- ~ Be sure to use the same type of polish consistently. Your furniture will appear cloudy or streaky if oil based or wax based polishes are interchanged.
- ~ Spray your furniture surface evenly. Wipe in a circular motion with a soft clean cloth.