







# ASSEMBLY INSTRUCTION

37-OT1020 End Table

Thank you for purchasing this quality product. Be sure to check all packing material carefully for small parts which may have come loose inside the carton during shipment. Identify, count all parts and compare with below parts list.

| Hardware List |   |               |              |        |
|---------------|---|---------------|--------------|--------|
| No.           | Image   | Desc.         | Size         | Q'ty   |
| A             |  | Bolt          | Ø1/4"*5/8"   | 18 Pcs |
| B             |  | Spring Washer | Ø1/4"*1.5mm  | 18 Pcs |
| C             |  | Flat Washer   | Ø13mm*1.0mm  | 18 Pcs |
| D             |  | "L" Glass Pad | 30*30*10*2mm | 4 Pcs  |
| E             |  | Allen Wrench  | 4mm          | 1 Pc   |

| Parts List |  |                  |       |
|------------|--|------------------|-------|
| No.        | Image  | Desc.            | Q'ty  |
| ①          |   | Side Panel       | 2 Pcs |
| ②          |   | Top Stretcher    | 2 Pcs |
| ③          |   | Bottom Stretcher | 2 Pcs |
| ④          |   | Top Shelf        | 1 Pc  |
| ⑤          |   | Bottom shelf     | 1 Pc  |
| ⑥          |  | Glass            | 1 Pc  |

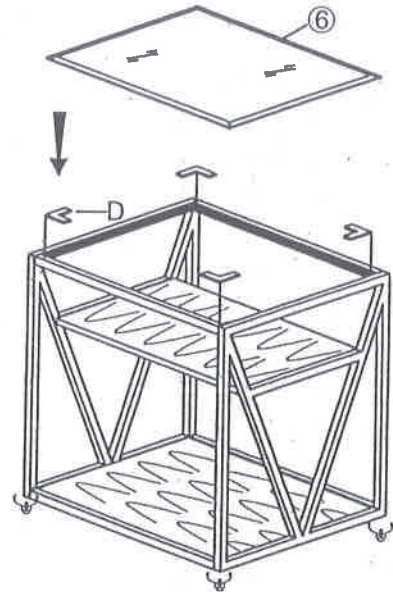

## Step 1

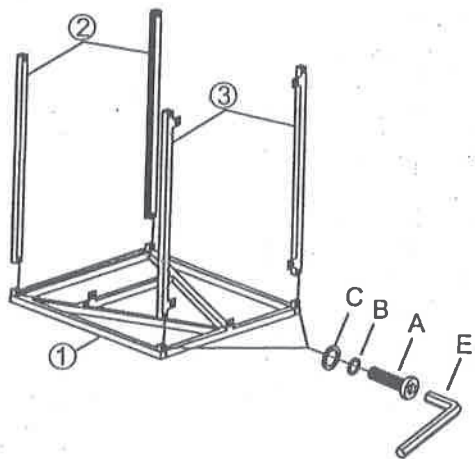

## Step 2

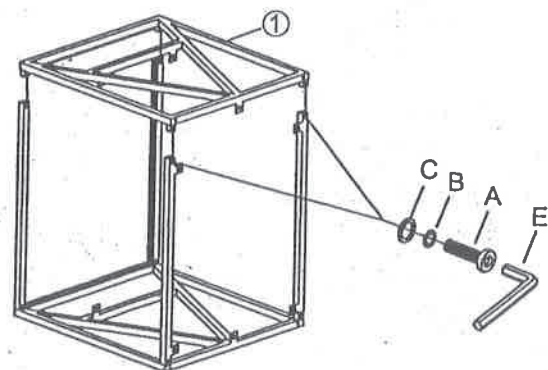

## Step 3

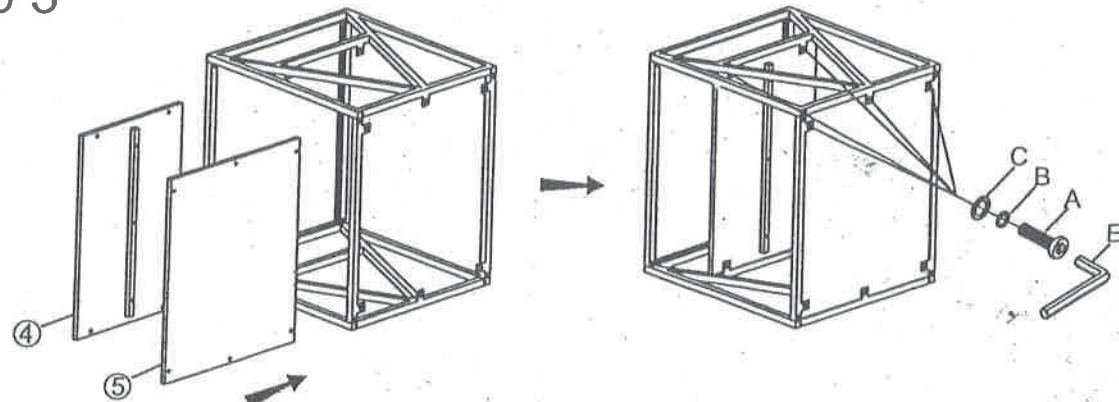

Cleaning Instructions: Clean the goods surface with furniture polish and a soft cloth.