





ASSEMBLY INSTRUCTION

Item: 7252-90351 -85 5/0 Panel Headboard
7252-90352 -85 5/0 Panel Footboard
7252-90353 -85 5/0-6/6 Rails



Thank you for purchasing this quality product. Be sure to unpack carefully looking for small parts which may have come loose during shipment.

Read all instruction and study the drawing carefully before starting the assembly process.

HARDWARE PACK OF HEAD BOARD

NO.	DRAWING	DESCRIPTION	SIZE	QTY
A		Bolt	5/16"X2-1/2"	2pcs
B		Bolt	5/16"X2"	8pcs
C		Flat washer	5/16"X19X2	10pcs
D		Lock washer	5/16"X12X3	10pcs
E		Allen key	5mm	1pc

PART LIST

NO.	DRAWING	DESCRIPTION	QTY
①		Headboard	1pc
②		Stretcher	1pc
③		Leg	2pcs

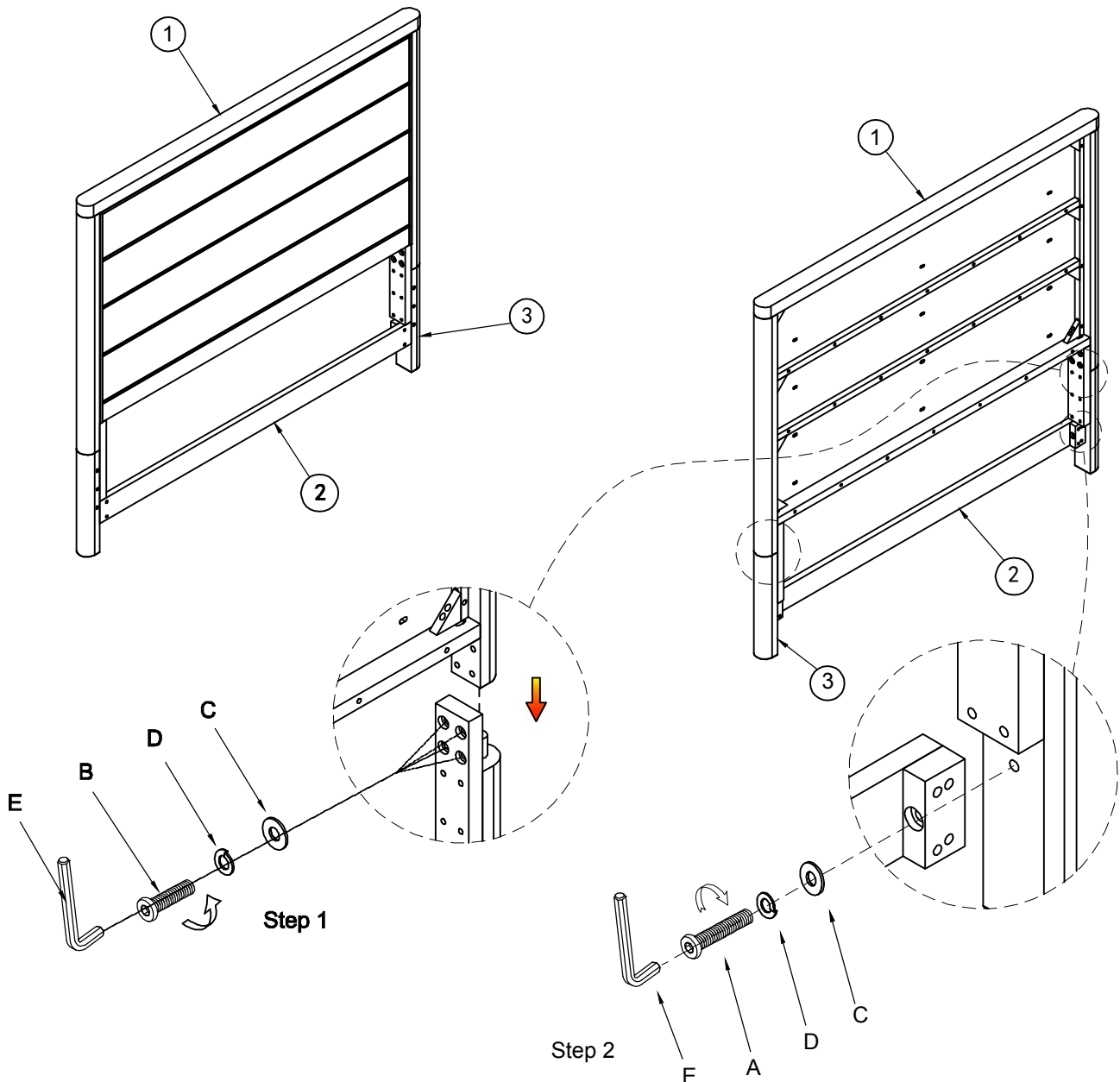





ASSEMBLY INSTRUCTION

Item : 7252-90351 -85 5/0 Panel Headboard
7252-90352 -85 5/0 Panel Footboard
7252-90353 -85 5/0-6/6 Rails





Thank you for purchasing this quality product. Be sure to unpack carefully looking for small parts which may have come loose during shipment.

Read all instruction and study the drawing carefully before starting the assembly process.

HARDWARE PACK OF RAILS

NO.	DRAWING	DESCRIPTION	SIZE	QTY
A		Threaded rod	5/16" x 4 1/2"	8pcs
B		Curved washer	L32x13x8	8pcs
C		Lock washer	5/16" x 12 x 3	8pcs
D		Nut	5/16" x 12	8pcs
E		Hex wrench	12mm	1pc

PART LIST

NO.	DRAWING	DESCRIPTION	QTY
①		Headboard	1pc
②		Footboard	1pc
③		Bed rails	2pcs
④		Wood slat	4pcs
⑤		Slat support leg	4pcs

HARDWARE PACK OF FOOTBOARD

NO.	DRAWING	DESCRIPTION	SIZE	QTY
F		Screw	8# x 1"	8pcs

