





PALECEK™

601 PARR BOULEVARD, RICHMOND, CA 94801

MONTERRA DINING TABLE INSTALLATION INSTRUCTIONS

These instructions are provided for your convenience. It is very important that they are read carefully and completely before beginning installation of this item. (Applies to items 7840-03)

HARDWARE LIST			
PART	DESCRIPTION		QTY
A		Hex Screw $\frac{5}{16}$ " x 1 5/8"	22
B		Lock Washer $\frac{5}{16}$ "	22
C		Flat Washer $\frac{5}{16}$ "	22
D		Allen Wrench	1

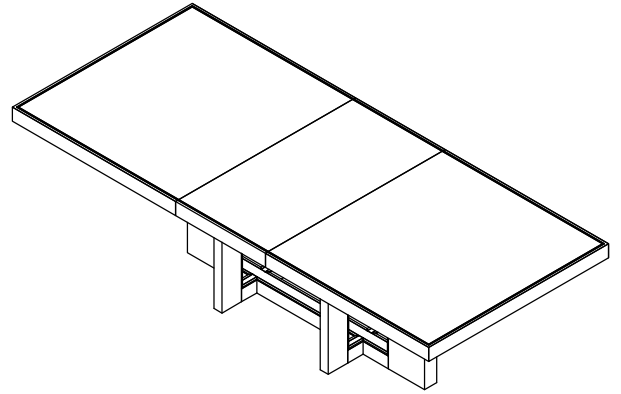

ITEM 7840-03

TOOLS NEEDED:

1. Allen Wrench (included).

TO ASSEMBLE:

1. Unbox all components onto a non scratching surface.
2. Ensure the TABLE BASE is in an upright position.
3. Carefully place MENDING BOARD BASE onto TABLE BASE, aligning the screw holes.
4. Insert a LOCK WASHER and a FLAT WASHER onto a HEX SCREW, and insert into the twelve (12) holes indicated in Diagram #1. Tighten with the included ALLEN WRENCH.
5. Place the TABLE TOP upside down on a non scratching surface.
6. Place the MENDING BOARD TOP onto underside of TABLE TOP, aligning the holes.

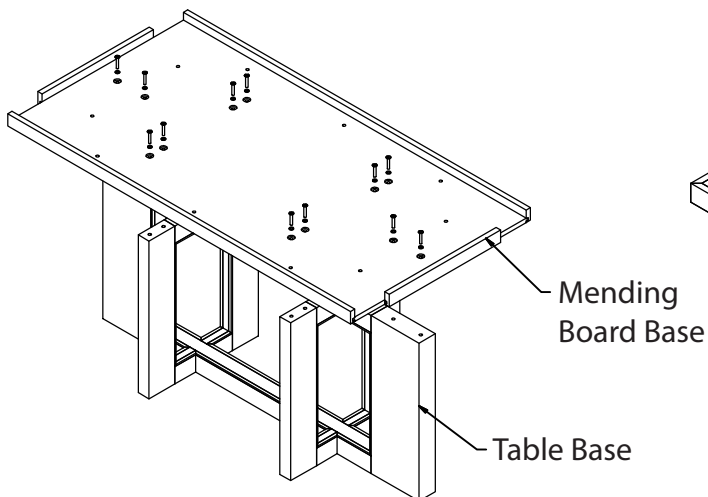

Diagram #1

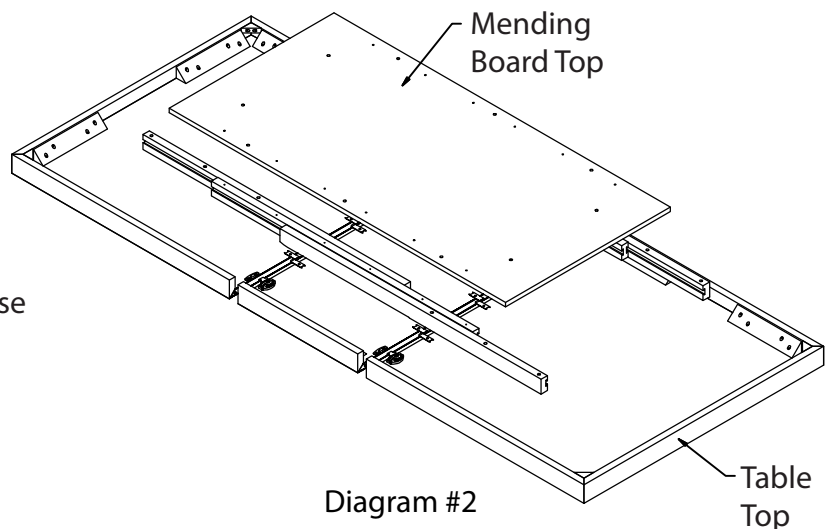

Diagram #2

PALECEK™

601 PARR BOULEVARD, RICHMOND, CA 94801

MONTERRA DINING TABLE INSTALLATION INSTRUCTIONS

TO ASSEMBLE (cont'd):

7. Carefully place TABLE BASE / MENDING BOARD BASE assembly upside down onto TABLE TOP / MENDING BOARD assembly and align holes.
8. Insert a LOCK WASHER and a FLAT WASHER onto a HEX SCREW, and insert into the ten (10) holes indicated in Diagram #3. Tighten with the included ALLEN WRENCH.
9. Carefully place assembled table in an upright position.
10. Assembly complete.

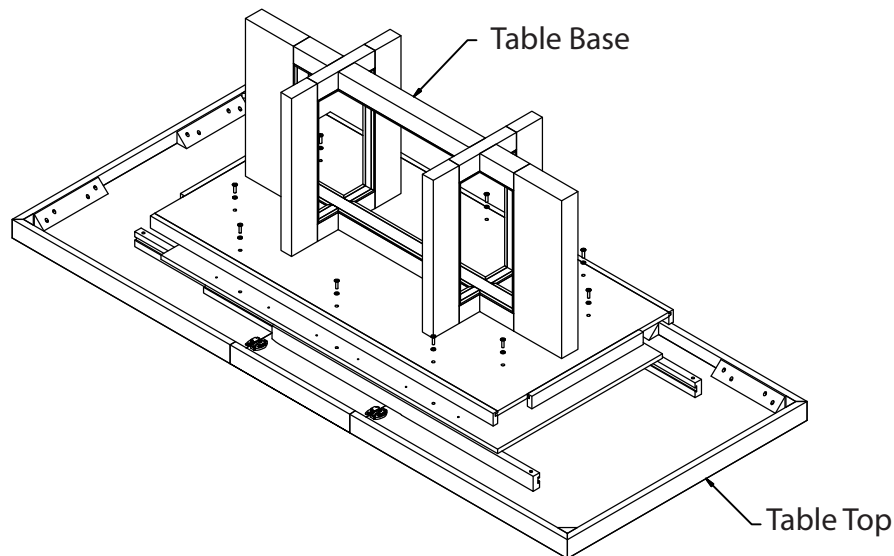

Diagram #3

CARE:

Dust with a soft dry cloth. Do not use cleaning solutions or abrasives.

T. 800.274.7730 | F. 510.234.7234

PALECEK.COM