

LINEA™ 6223

WORK DESK

INSTRUCTION MANUAL



DESIGN MATTHEW WEATHERLY

BDi

BDIUSA.COM



Congratulations on the purchase of your Linea Work Desk 6223 from BDI. Your desk has been designed to provide a lifetime of enjoyment. This manual will provide you with assembly instructions and other helpful information that will ensure that you get the most out of your product. Please save it for future reference.

Your Linea Work Desk has been engineered for simple assembly. Please follow these directions carefully to prevent any damage.

Should you need further assistance, contact BDI at customerservice@bdiusa.com.

ENJOY!

HARDWARE AND COMPONENTS

Unpack and identify the parts listed below. The assembly workspace should be a non-marring surface such as carpet. For missing hardware pieces, please contact BDI Customer Service at customerservice@bdiusa.com.

Do not use power tools for the assembly of this product.

For all other concerns, please contact your BDI retailer.



PART #	T1
DESCRIPTION	Hex Wrench
QUANTITY	1



PART #	H1
DESCRIPTION	M6 x 10mm Screw
QUANTITY	10

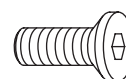

PART #	H2
DESCRIPTION	M6 x 16mm Screw
QUANTITY	6

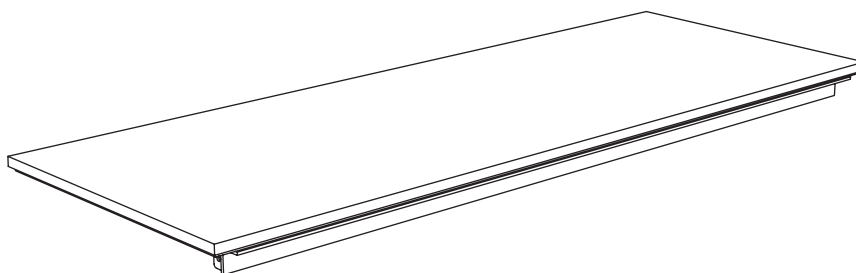

PART #	C1
DESCRIPTION	Top Panel
QUANTITY	1

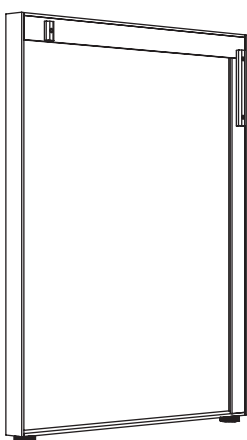

PART #	C2
DESCRIPTION	Leg Frame – Left
QUANTITY	1

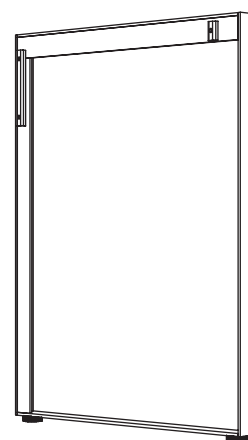

PART #	C3
DESCRIPTION	Leg Frame – Right
QUANTITY	1

HARDWARE AND COMPONENTS

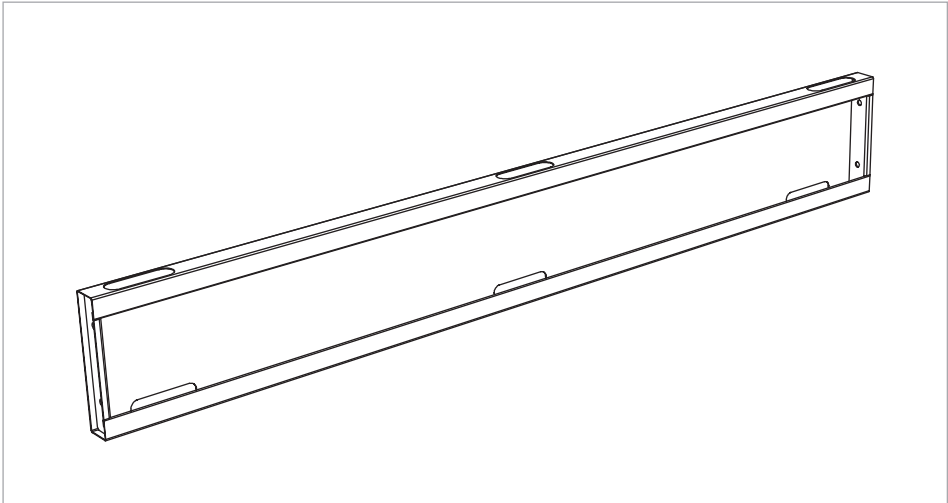

PART #	C4
DESCRIPTION	Wire Trough
QUANTITY	1

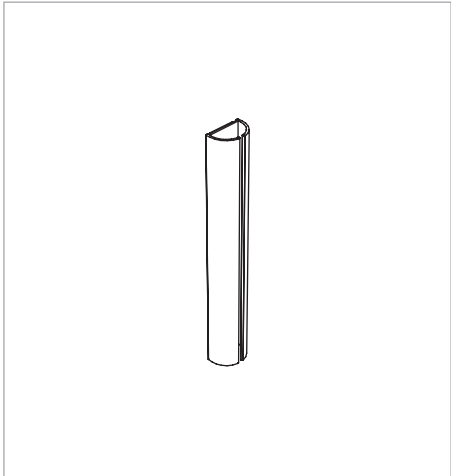

PART #	C5
DESCRIPTION	Wire Management Extrusion
QUANTITY	1

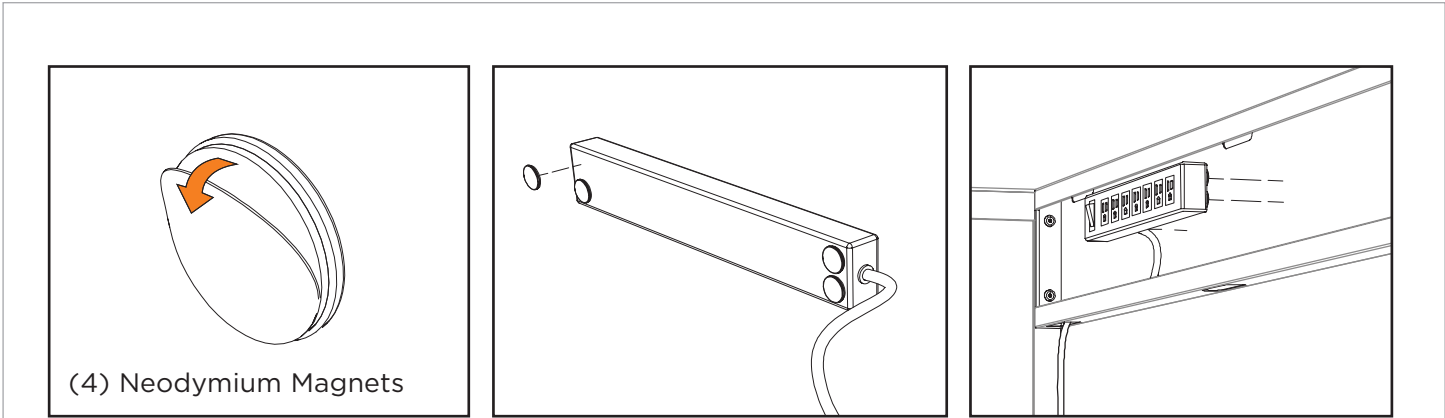

PART #	C6
DESCRIPTION	Power Strip Mounting Kit
QUANTITY	1

Connect **(C4) Wire Trough** to **(C1) Top Panel Assembly** using **4 (H1) Screws**. Partially tighten with **(T1) Hex Wrench**. The **(C4) Wire Trough** is reversible and can be installed facing toward the front or back of the desk as needed.

	PART/DESCRIPTION	QTY
	T1-HEX WRENCH	1
	H1-SCREW	4

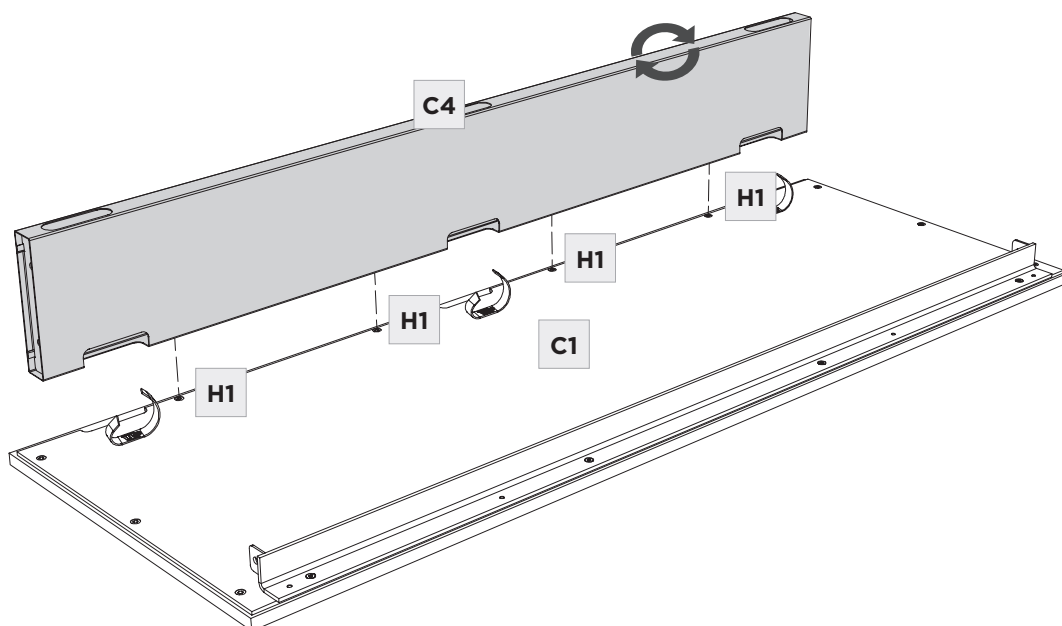
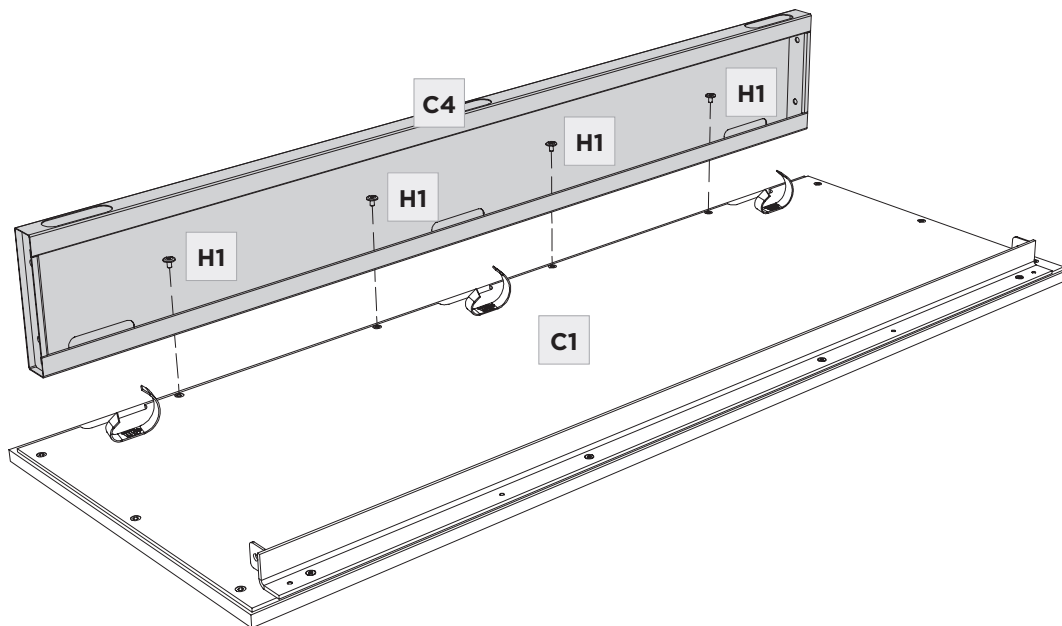



STEP 2. ATTACH LEG FRAMES

ASSEMBLY

Connect **(C2) Left Leg Frame** to **(C4) Wire Trough** using **2 (H1) Screws**. Fasten to **(C1) Top Panel Connection Tab** using **1 (H1) Screw**. Partially tighten screws.

Connect **(C3) Right Leg Frame** to **(C4) Wire Trough** using **2 (H1) Screws**. Fasten to **(C1) Top Panel Connection Tab** using **1 (H1) Screw**. Partially tighten screws.

	PART/DESCRIPTION	QTY
	T1-HEX WRENCH	1
	H1-SCREW	6

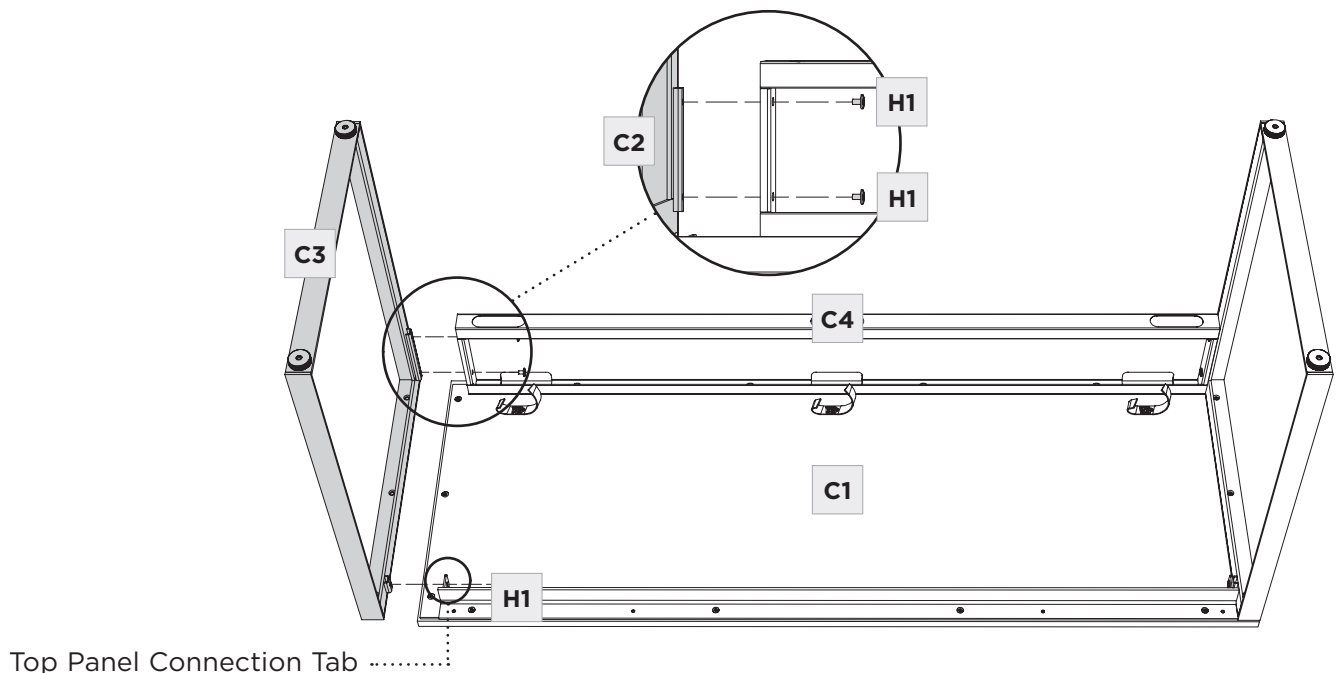
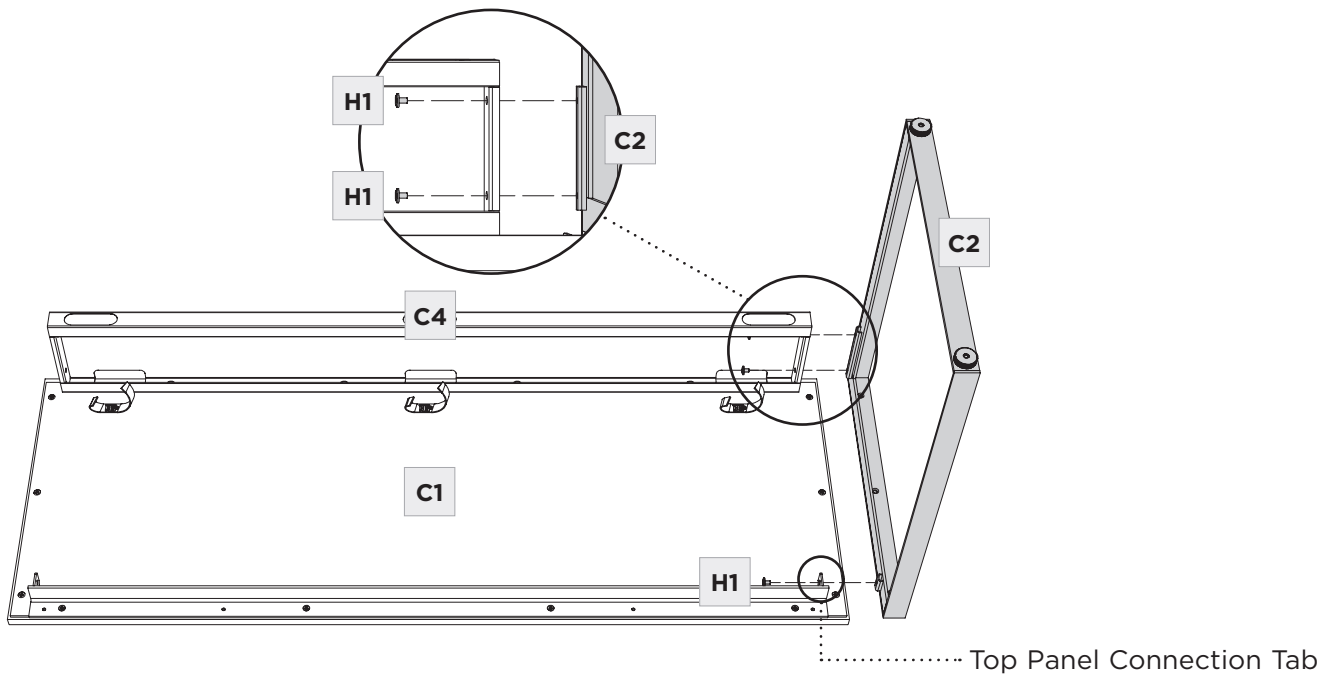

Fasten **(C2)** and **(C3)** Leg Frames to **(C1)** Top Panel using **(H2)** Screws. Tighten all screws connecting **Legs** and **Wire Trough**.

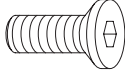
	PART/DESCRIPTION	QTY
	T1-HEX WRENCH	1
	H2-SCREW	6

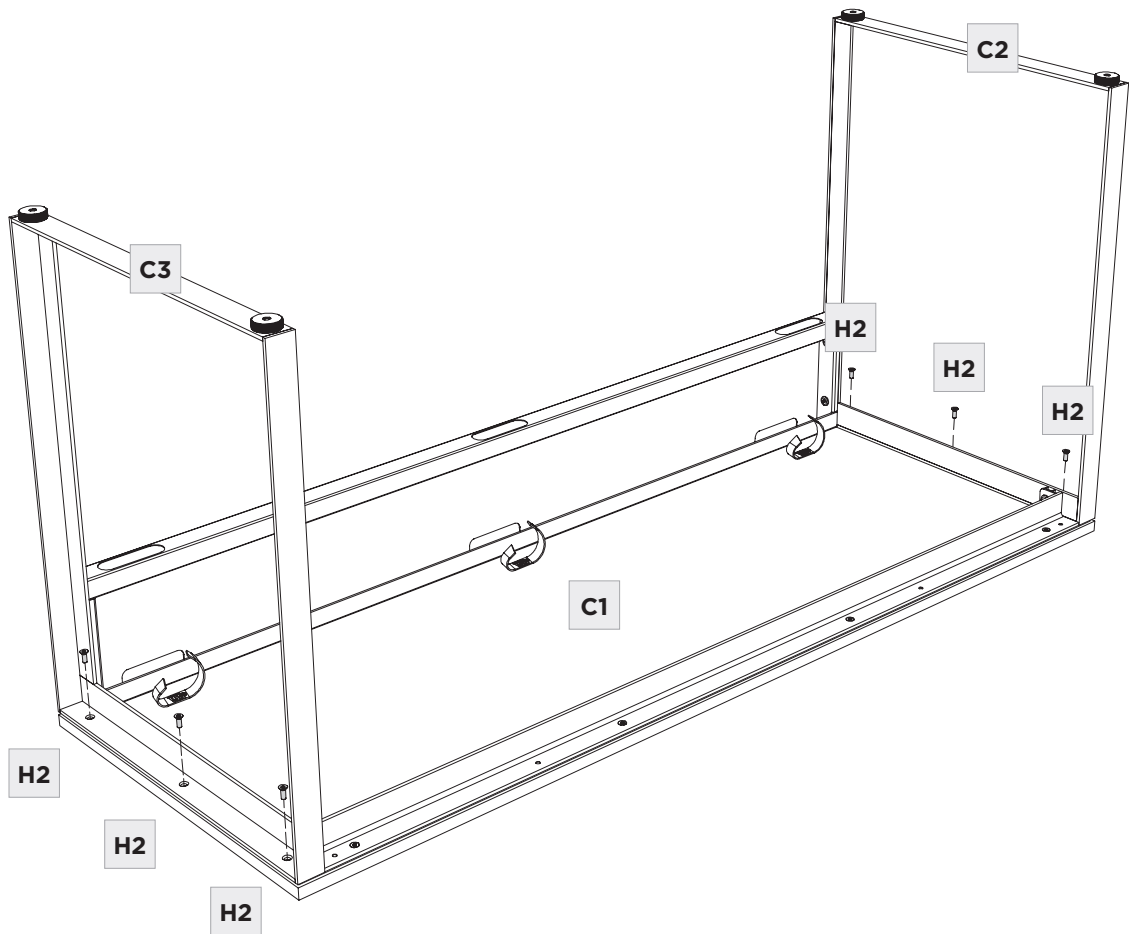

STEP 4. INSTALL WIRE MANAGEMENT EXTRUSION
—OPTIONAL



ASSEMBLY

With help from another person, carefully position your Linea Work Desk onto its base. Once the desk is upright, install the **(C5) Wire Management Extrusion** on the leg of your choice.

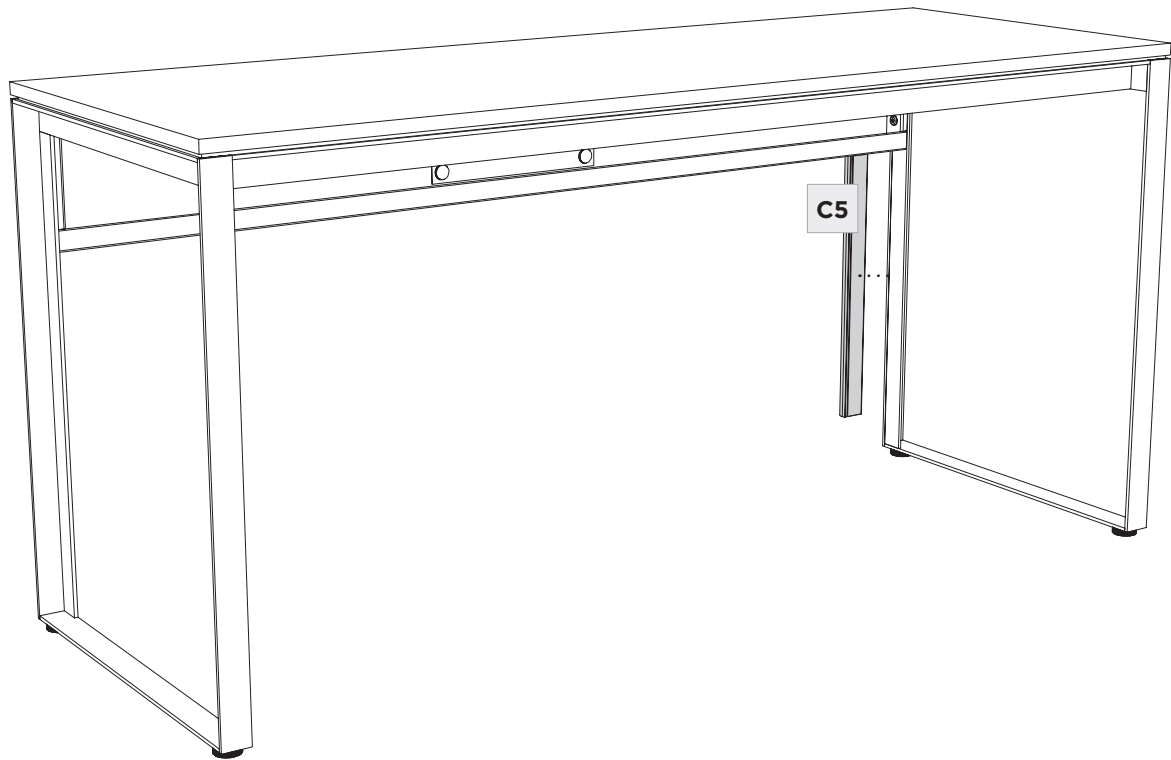

FINE TUNING

POWER STRIP MOUNTING KIT (Power strip not included)

(4) Neodymium Magnets

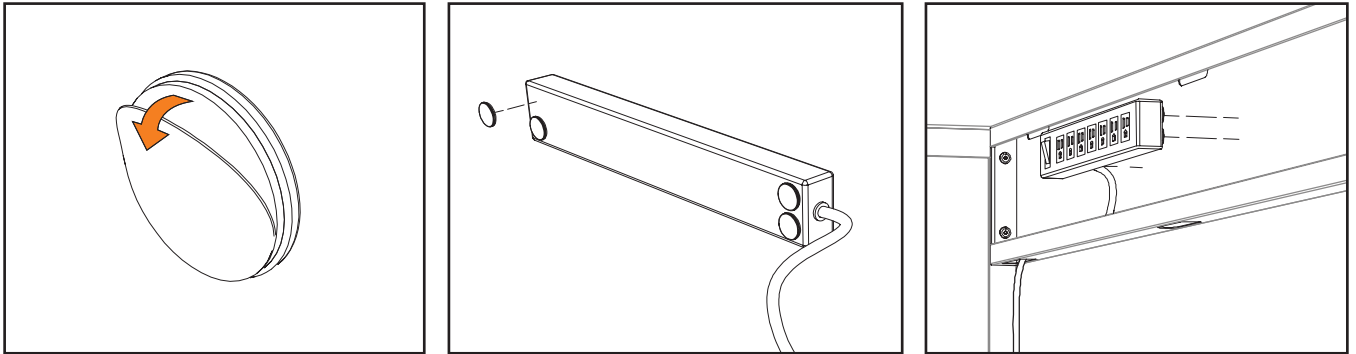

Your Linea Work Desk is equipped with built-in levelers. Dial down one or more levelers (by hand) until you attain a level stance.

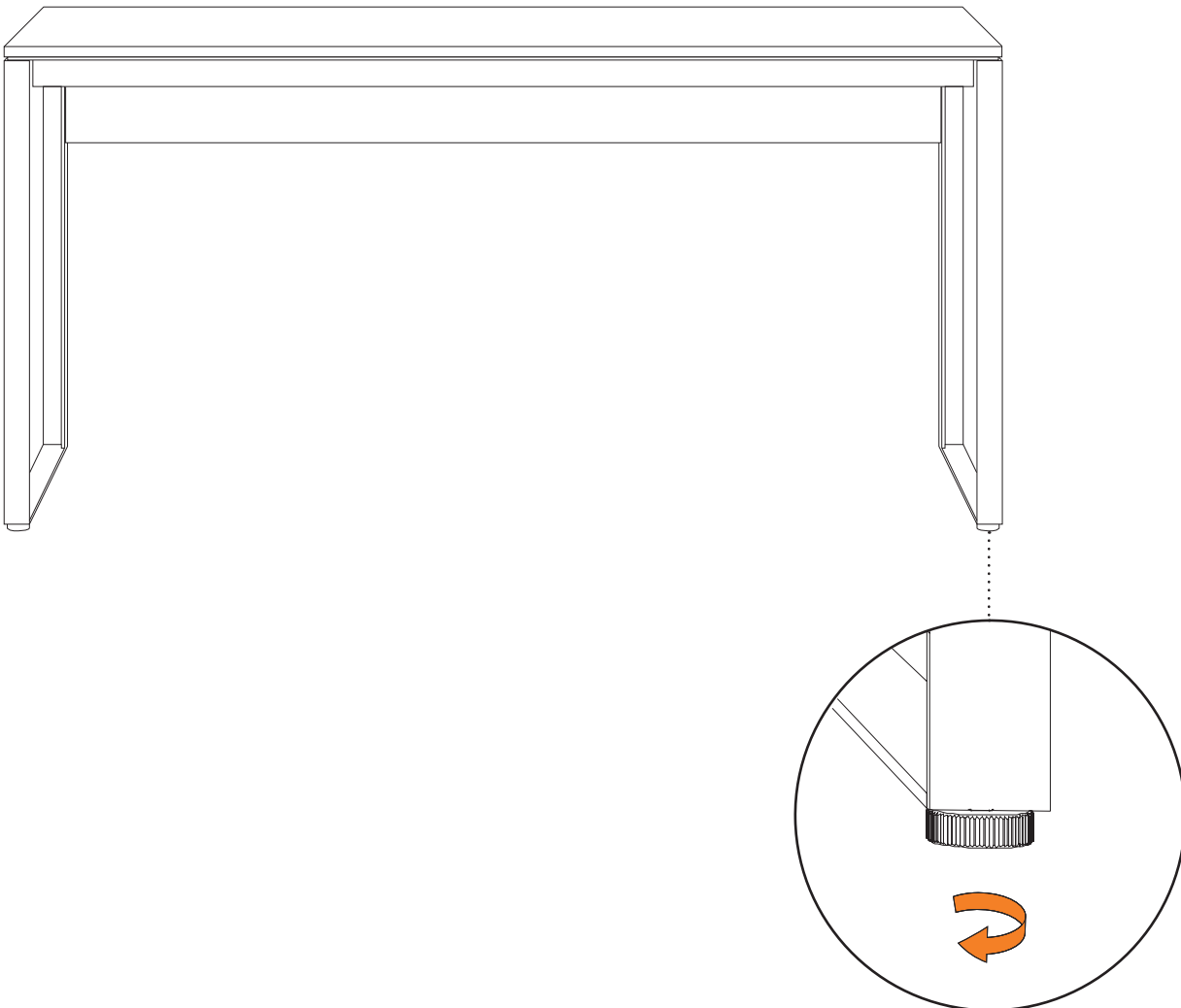

Dial down

GLASS

The glass surface is maintained using household glass cleaner and a paper towel or cloth.

SATIN-ETCHED GLASS

This uniquely smooth-to-the-touch glass surface can be regularly maintained using household glass cleaner and a paper towel or cloth. Minor scratches or scuffs not eliminated using paper towel or cloth can usually be removed by using a 'Magic Eraser'. Magic Eraser is a melamine foam product available at any grocery store or home improvement center. Dampen the entire glass surface and the Magic Eraser, then rub the entire glass surface in broad, even strokes using moderate pressure. Clean and dry the surface with a paper towel. Check for results and repeat as necessary.

Any scratches or scuffing not eliminated by one of the above methods can often be addressed by 'refreshing' the glass. This is a process that should not be required more than once per 6-12 months. See this brief video for the simple method: www.bdiusa.com/glass

WOOD

Wood surfaces should be cleaned with a slightly damp (not saturated) cloth or paper towel. Do not use glass cleaner on wood. If moisture remains, dry the surface with another cloth. If needed, a gentle non-abrasive cleanser may be used, but be sure to wipe away all cleaner residue and dry the surface with a cloth.

BDI's wood finishes feature natural hardwood solids and veneers. Wood is a product of nature and—unlike man-made materials that can be manufactured to strict and consistent specifications—has natural imperfections that are part of its appeal and character. Every piece of wood differs from every other, even when coming from the very same tree. As such, variation in grain, texture and tone should be expected from one panel or piece of furniture to the next.

While BDI's stained wood finishes are stable in tone & appearance, all finishes are subject to some degree of discoloration with prolonged exposure to direct sunlight. Please take care to avoid positioning your BDI cabinet in any area with extensive direct sunlight. To learn more about the features of natural wood, visit www.bdiusa.com/wood

METAL & PAINTED SURFACES

Surfaces should be cleaned with a slightly damp (not saturated) cloth or paper towel. If moisture remains, dry the surface with another cloth. If needed, a gentle non-abrasive cleanser may be used, but be sure to wipe away all cleaner residue and dry the surface with a cloth.

WARRANTY

BDI warrants to the original purchaser that for the below-stated warranty term, BDI will replace any product, part, or component covered by this warranty that fails under normal use as a result of a defect in material or workmanship. The decision to replace a complete product versus the part or component in question will be at BDI's sole discretion.

Residential Use: BDI Furnishings carry warranty coverage for three (3) years from the date of product delivery, as shown on your sales receipt/documentation. Select chairs carry coverage for five (5) years from the date of product delivery.

Commercial Use: BDI Furnishings carry warranty coverage for one (1) year from the date of product delivery, as shown on your sales receipt/documentation. Select chairs carry coverage for five (5) years from the date of the product delivery, based on an 8-hour daily use pattern.

BDI reserves the right to refine or update its warranty from time to time. See the complete and latest warranty document at www.bdiusa.com/warranty.

PRODUCT REGISTRATION

Registering your new BDI product allows us to send you important product updates, service information, and helpful hints related to your BDI products. Register today, and you will be entered to win free a BINK table from BDI: www.bdiusa.com/register



WARNING

SERIOUS OR FATAL CRUSHING INJURIES CAN OCCUR FROM FURNITURE TIP-OVER. TO HELP PREVENT TIP-OVER:

- Install tip-over restraint.
- Place heaviest items in lower compartments.
- Never allow children to climb or hang on drawers, doors, or shelves.
- Never open more than one drawer at a time.

USE OF TIP-OVER RESTRAINT MAY REDUCE—BUT NOT ELIMINATE—THE RISK OF TIP-OVER.



BDIUSA.COM

These distinctive product configurations are protected by US and international patents, trade dress, and/or copyright laws. Linea & BDI are trademarks of Becker Designed, Inc. All rights reserved. ©2021, BDI | V.03.02.2021

Made in Vietnam.