



Parker Living  
A Division of Parker House

# Assembly Instructions

## Hancock Drop Down Table Sofa

### BEFORE ASSEMBLY

Thank you for purchasing this quality product. This product has been designed for easy assembly and constructed for durability. Please take the time to read and follow the assembly instructions carefully.

### Power Zero Gravity Drop Down Table Sofa P3

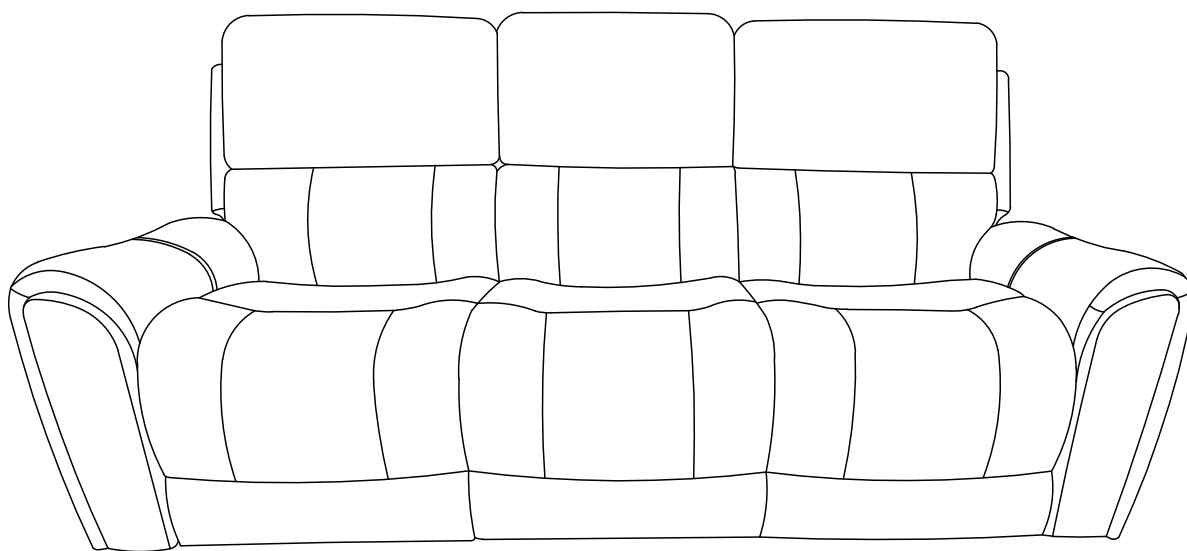

### Part List

When unpacking, please be careful not to discard any parts with the packaging. Before continuing, please make sure you have the following parts:

NO	Description	Sketch	Qty
A	Body		1 PC
B	LAF Back Cushion		1 PC
C	Middle Back Cushion		1 PC
D	RAF Back Cushion		1 PC
E	LAF Wing		1 PC
F	RAF Wing		1 PC
G	Plug Transformer		1 PC
H	Plug Transformer 2		1 PC

## Step 1

1. Remove Plug Transformer (G) and Plug Transformer (H) from the bottom of the Body (A).
2. Remove LAF Wing (E) and RAF Wing (F) from the back of the Body (A).

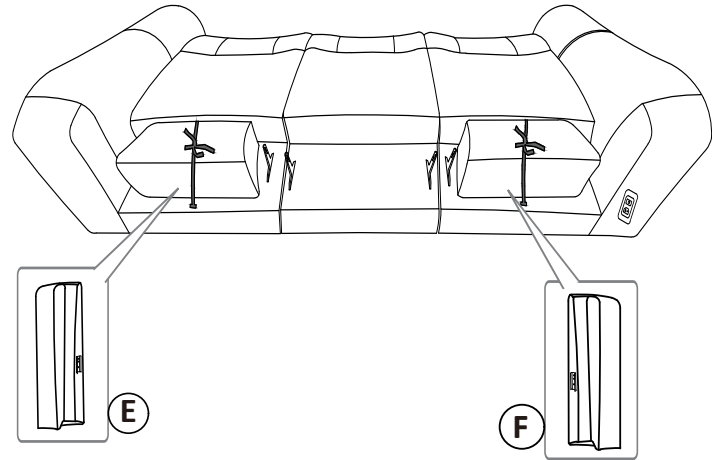
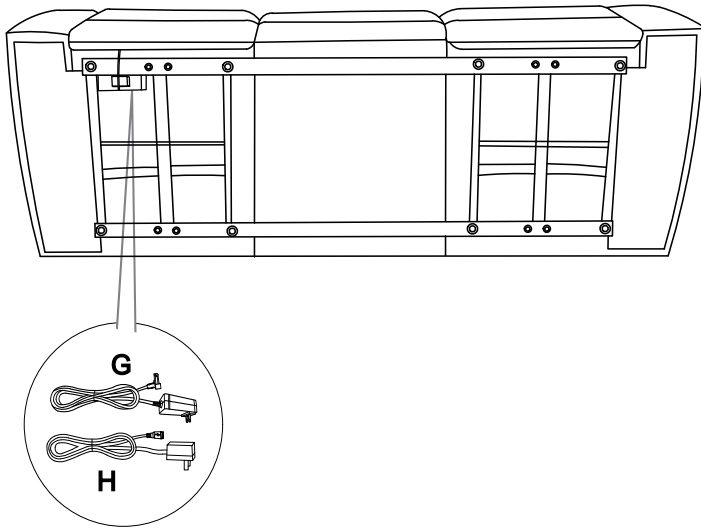

## Step 2

1. Install the Backrest (B/C/D) into the Seat (A) by positioning the female metal receiver brackets over the male metal posts. Ensure that female metal receiver brackets on each side of the backrest are lined up with the seat metal posts. Push down the female brackets over male posts simultaneously until each side is locked into place and an audible "click" is heard.

2. The power cables on the backrest (B,D) and seat (A) are labeled (Head and Lumbar) please connect each wire correctly.

- Connect the "Head" wire to the "Head" wire.

- Connect the "Lumbar" wire to the "Lumbar" wire.

3. Connect the Middle Back Cushion (C) reading light power cables to the seat power cables (A).

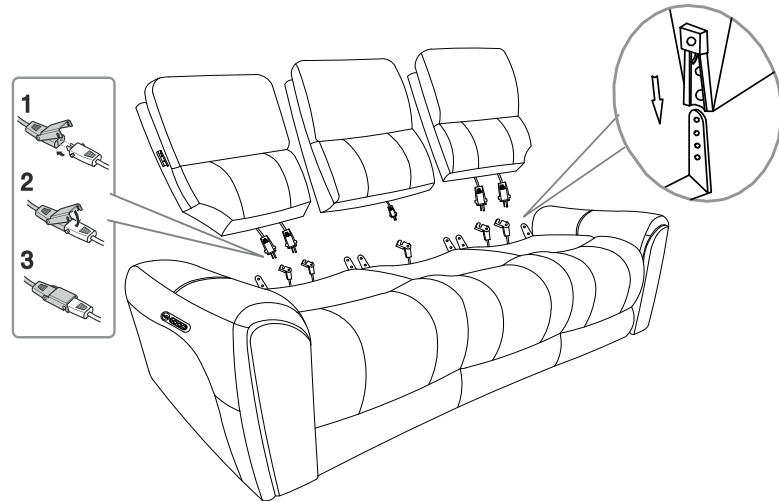

## Step 3

Install the LAF Wing (E) and RAF Wing (F) by sliding wings in a downward motion along the side of the seat back to connect the brackets.

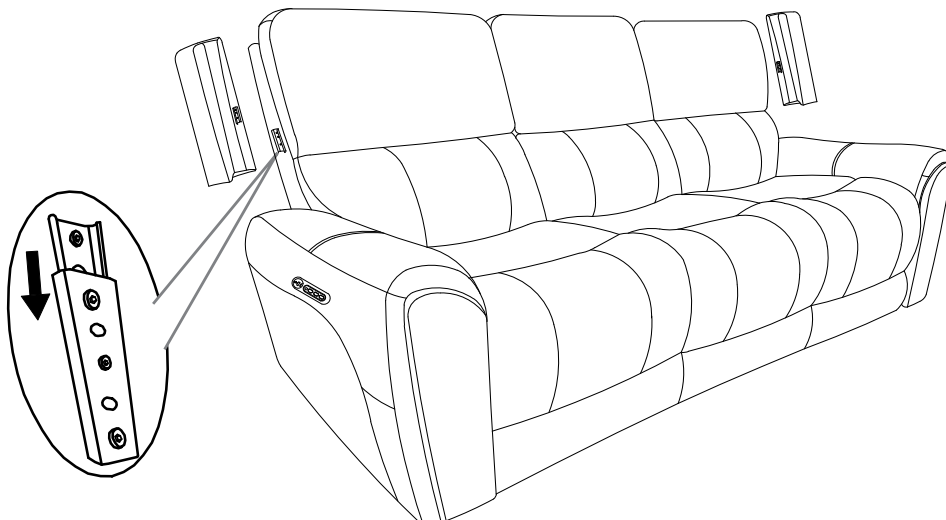

## Step 4

**1. Insert the AC power plug behind the Middle backrest firmly into the wall outlet/power strip.**

**2. Firmly insert one end of the wall plug transformer cord (H) into the wireless charger's USB DC power connector on the back of the Middle Back Cushion and plug the other end into a wall outlet/power strip.**

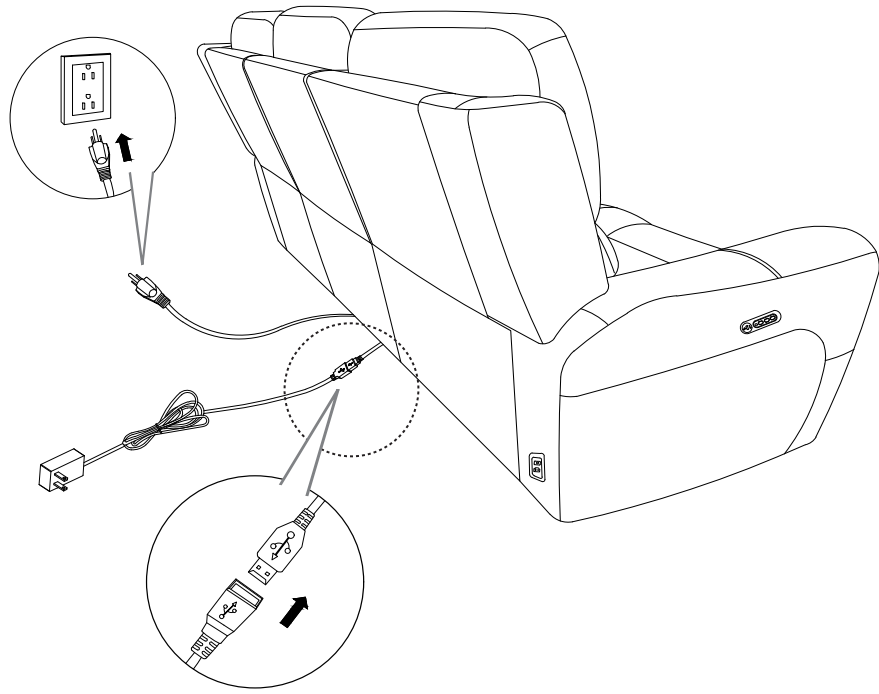

## Step 5

**1. Attach the flap to the seat frame by pulling the flap down, and pressing the bottom under the seat base, connecting the velcro.**

**2. Connect firmly one end of the wall plug transformer cord into the DC adapter located in the lower back corner of Recliner and plug the other end into a power outlet/wall socket and enjoy.**

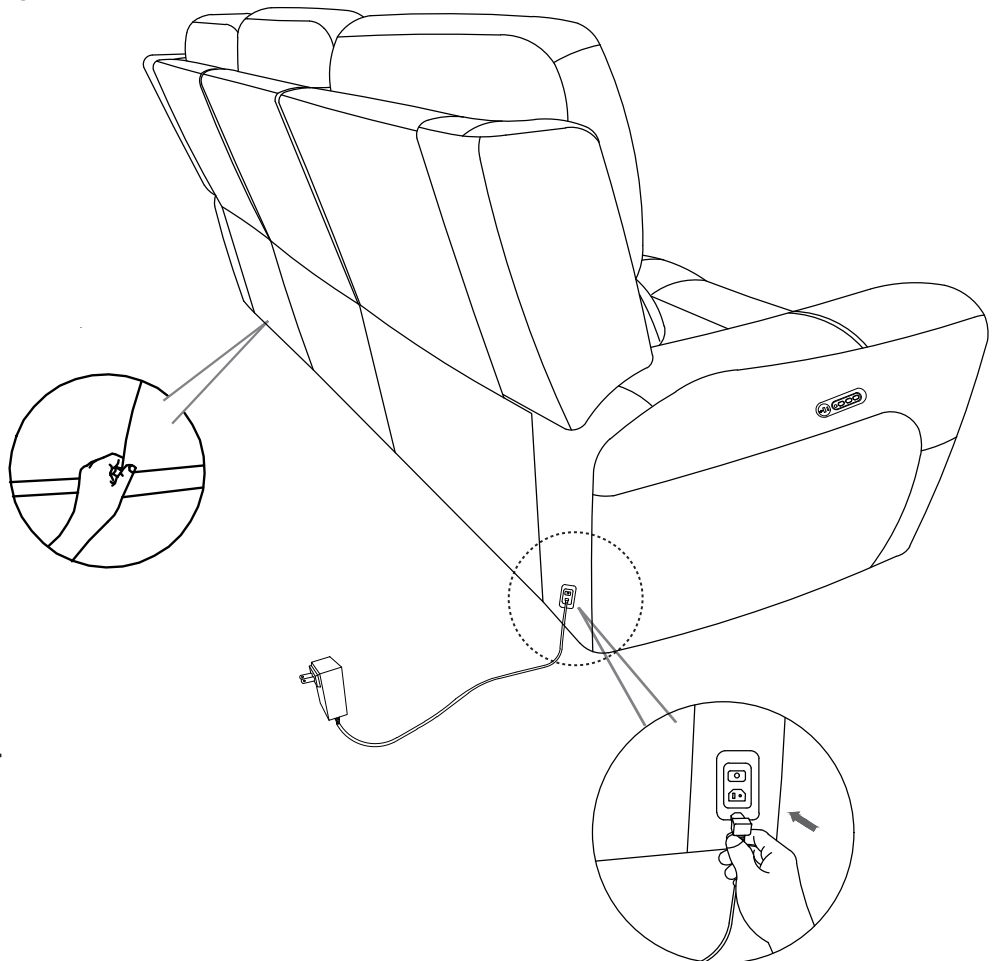

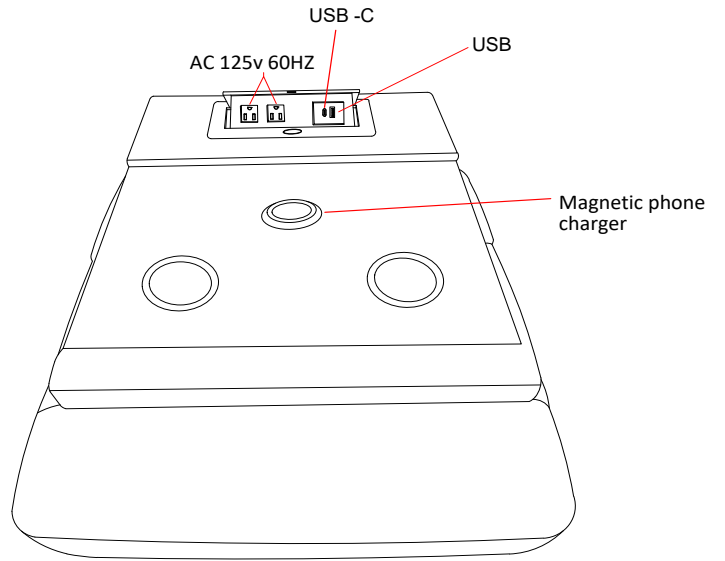
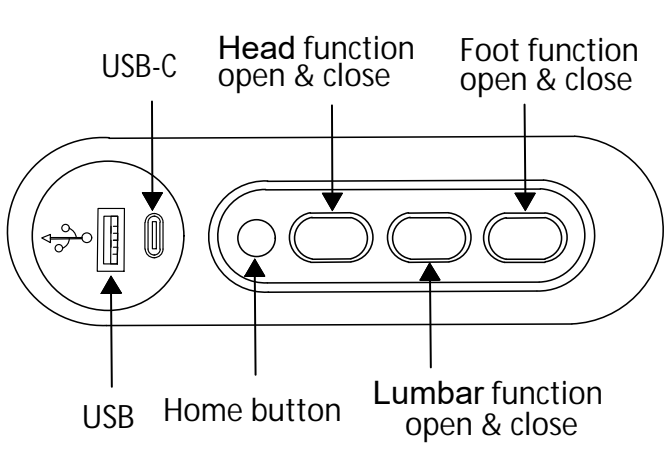

### Function Display

