

EST. *B* 1991

BRAMBLE

PRODUCT TEARSHEET



# Ellipse Chandelier

---

Shown in: **DRW**

SKU: **95014**

Size: **31W x 31D x 39H in**



# Overview

---

Ellipse Chandelier

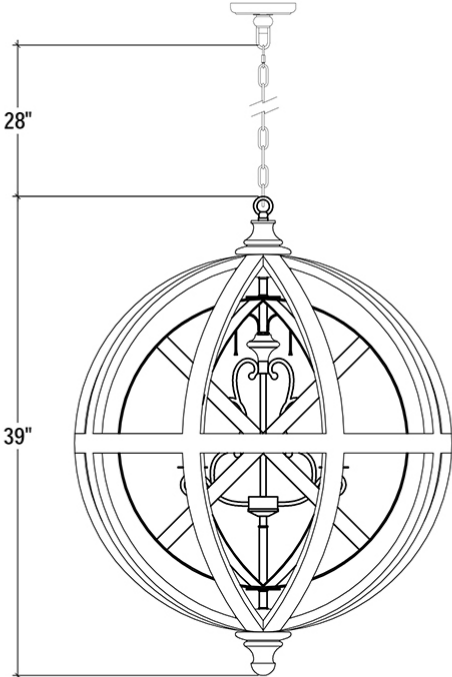

FRONT VIEW

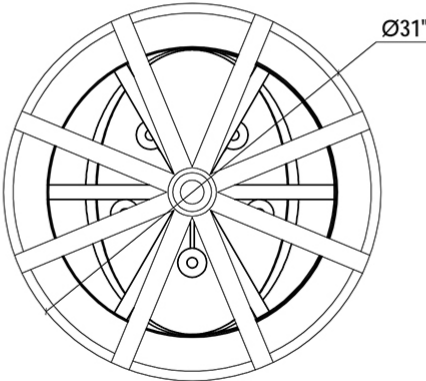

TOP VIEW

## Visual Highlights

---



## Technical Specification

---

Dimensions	<b>31W x 31D x 39H in</b>	CBM	<b>0.867328</b>
Number of Packages	<b>1</b>	Cubic Feet	<b>30.63 ft<sup>3</sup></b>
Package 1 Dimensions	<b>36.2 x 36.2 x 46.9 in</b>	Package 1 Weight	<b>33.07 lbs</b>
Package Weight Total	<b>33.07 lbs</b>	Net Weight	<b>28.59 lbs</b>

Material	<b>Mahogany</b>
Bulb Type	<b>E12</b>
Bulb Wattage	<b>40W</b>
No of Lights	<b>4</b>
Cable Length	<b>90.55</b>
Rope Length	<b>75</b>
Chain Length	<b>72.05</b>

<https://www.brambleco.com/95014>

---