



BRAMBLE

PRODUCT TEARSHEET



Alexander Nightstand

Shown in: **BBA**

SKU: **28396**

Size: **28W x 18D x 30H in**



Overview

Alexander Nightstand

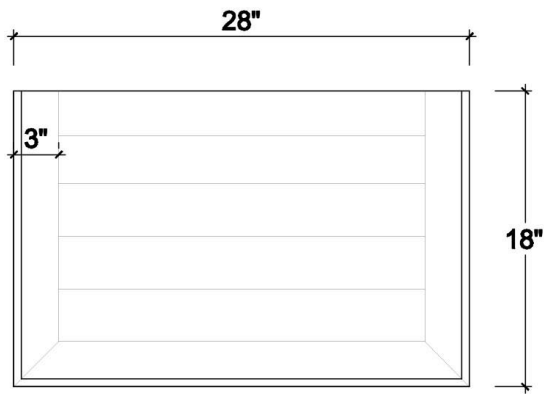

TOP VIEW

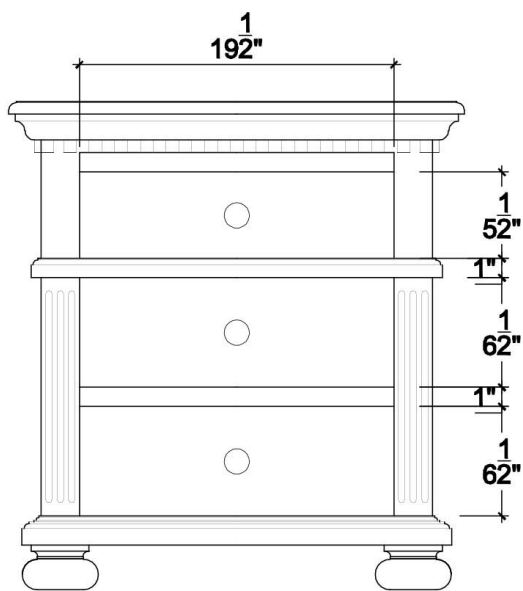

FRONT VIEW

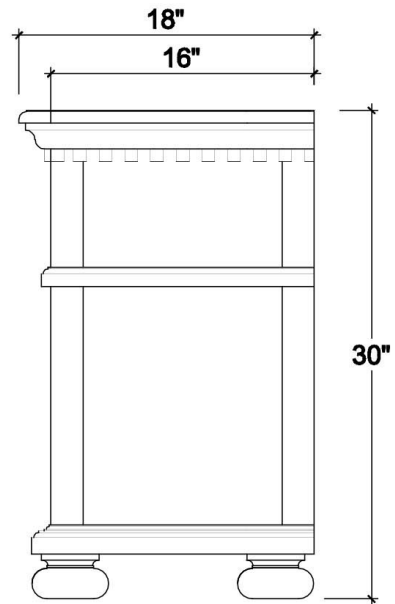

SIDE VIEW

Visual Highlights



Technical Specification

Dimensions	28W x 18D x 30H in	CBM	0.31125
Number of Packages	1	Cubic Feet	10.99 ft³
Package 1 Dimensions	29.5 x 19.7 x 32.7 in	Package 1 Weight	44.09 lbs
Package Weight Total	50.71 lbs	Net Weight	44.09 lbs
Material	Mahogany		

<https://www.brambleco.com/28396>
