

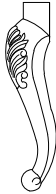

# ASSEMBLY INSTRUCTIONS FOR ACME FURNITURE

## MODEL: LV03826

Thank you for purchasing the quality product. Be sure to check all packing material carefully for small parts which may have come loose inside the carton during shipment. Separate, Identify and count all parts and metal hardware. Compare with all parts listed to be sure all parts are present. If any part(s) are missing or damaged, please contact your local furniture dealer. For efficient and speedy service, please indicate the model number and code letter of part(s) needed.

**\*\*Do not fully tighten screws until fully assembled\*\***

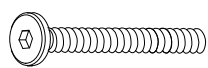
COMPONENT PARTS			
NO.	DESC.	SKETCH	QUANTITY
A	TABLE TOP		1 PC
B	LEG		4 PCS

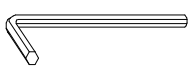
HARDWARE REQUIRED			
NO.	DESCRIPTION	SKETCH	QUANTITY
C	BOLT (Ø5/16x3 1/2"-RBW)		8 PCS
D	FLAT WASHER (Ø5/16"-RBW)		8 PCS
G	LOCK WASHER (Ø5/16"-RBW)		8 PCS
E	ALLEN KEY (5MM-RBW)		1 PC

### Attention

\*\*\*Some number parts listed on the instruction sheet may not be in parts bag as they may be assembled. Carefully check parts and packing materials prior to ordering replacements. \*\*\*

# ASSEMBLY INSTRUCTIONS FOR ACME FURNITURE

## MODEL: LV03826

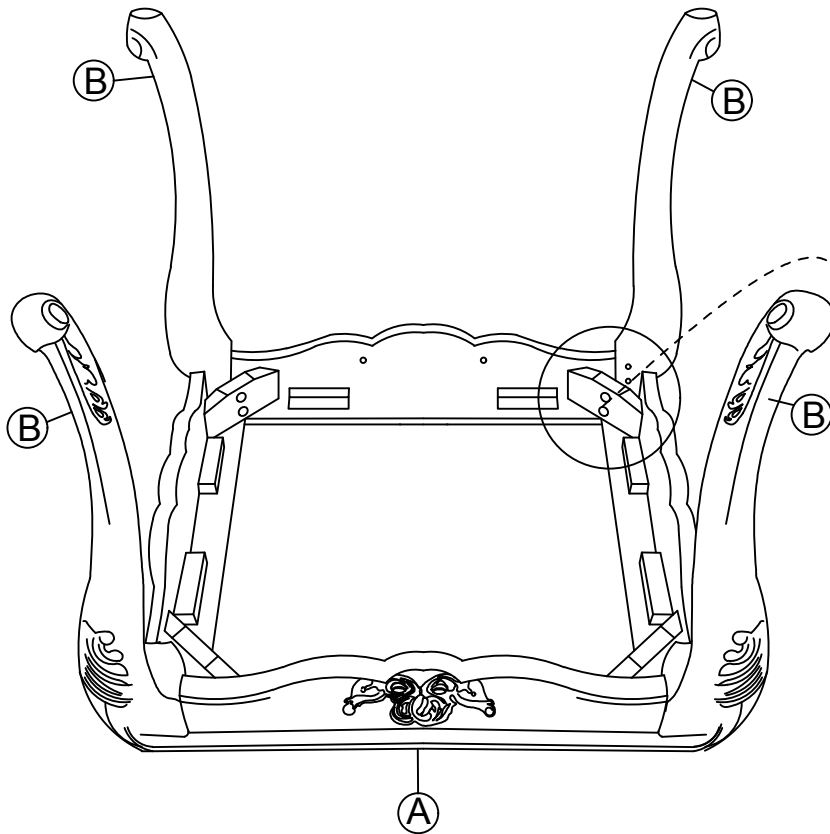

### **STEP 1:**

Lay the table top (A) to reach the holes to secure the bolts for the legs. Align and assemble the legs (B) to the table top (A) by using the Allen Key (E) with hardware C, G, and D.

### **COMPLETE :**

Your product is ready for you to enjoy.

