



ASSEMBLY INSTRUCTION FOR ACME FURNITURE







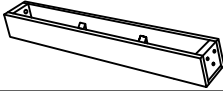
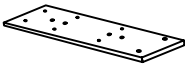



MODEL #DN04665

Thank you for purchasing the quality product. Be sure to check all packing material carefully for small parts which may have come loose inside and carton during shipment. Separate, identify and count all parts and metal hardware. Compare with all parts listed to be sure all parts are present. If any part(s) are missing or damaged, please contact your local furniture dealer. For efficient and speedy service, please indicate the model number and code letter of part(s) needed.

*** Do not fully tighten screws until fully assembled ***

COMPONENT PARTS			
DESCRIPTION	PART NAME		QTY (PCS)
①	TABLE TOP		1
②	LEGS		2
③	CENTER SUPPORT		1
④	TOP SUPPORT		2

HARDWARE REQUIRED

(A)		HEX HEAD	M/S M8X50MM	6pcs
(B)		FLAT WASHER	M8	6pcs
(C)		SPRING WASHER	M8	6pcs
(D)		SPANNER	13MM	1pc
(E)		JCBC	M6x35mm	24pcs
(F)		FLAT WASHER	M6x13mm	8pcs
(G)		SPRING WASHER	M6	24pcs
(H)		FLAT WASHER	M6X19mm	16pcs
(I)		ADJUSTABLE	M6X20mm	4pcs
(J)		ALLEN KEY	M4	1pc

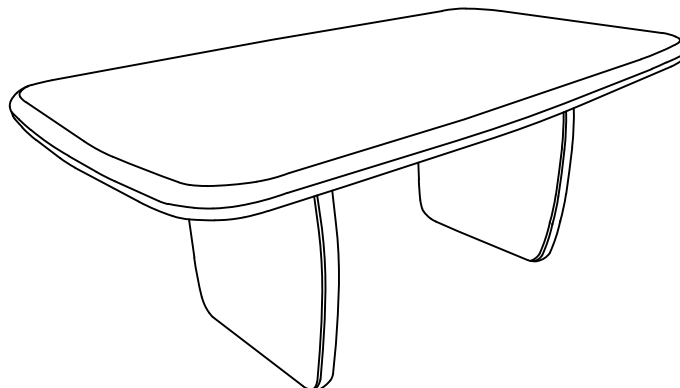

Attention

*** Some number parts listed on the instruction sheet may not be in parts bag as they may already be assembled. Carefully check parts and packing materials prior to ordering replacements. ***

How to assemble:

STEP 1

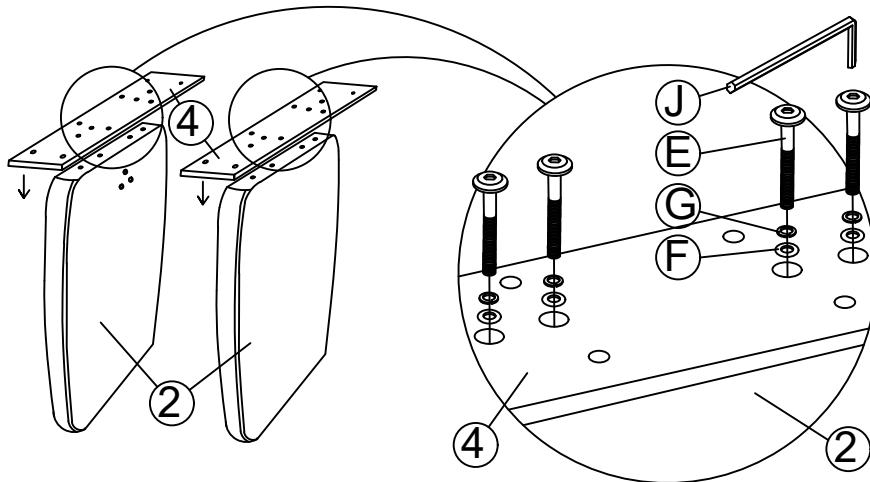

STEP 2

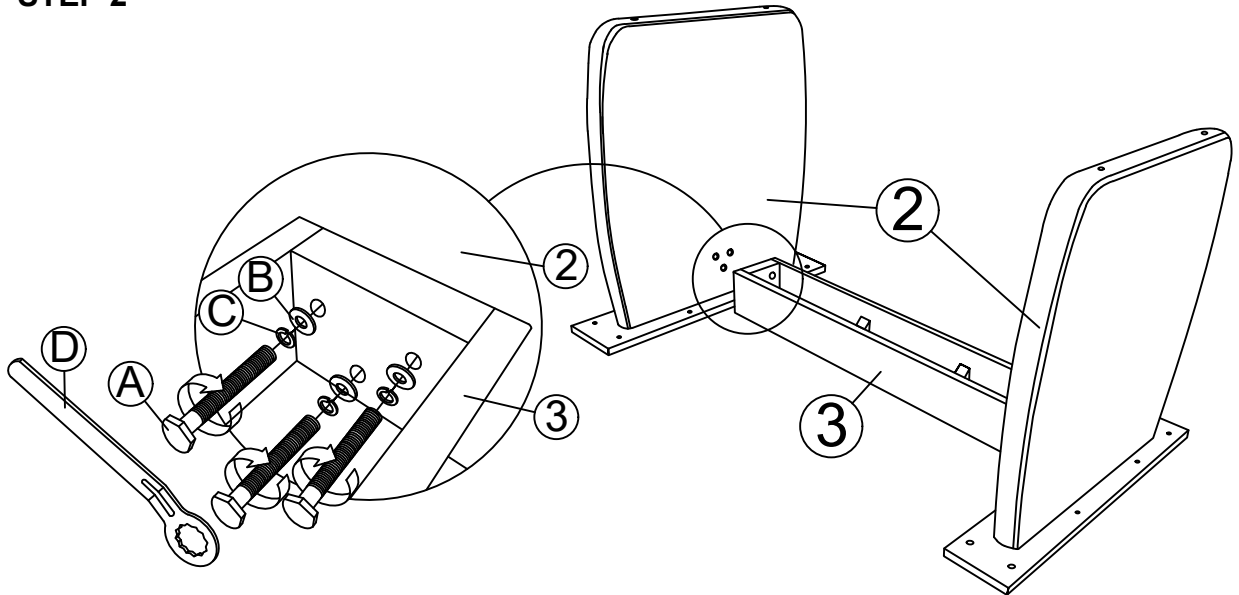

STEP 3

