

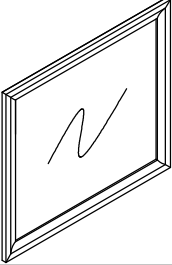

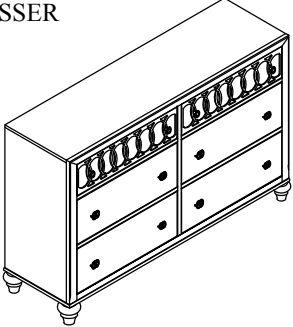
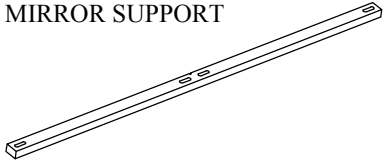

ASSEMBLY INSTRUCTION

MODEL :
 FBDSRA-088A + FBMIRR-088A
 REVISION : A

NO	PARTS & HARDWARE	QTY.
A	MIRROR 	1PC
B	DRESSER 	1PC
C	MIRROR SUPPORT 	2PCS
D	JCBC M6 x 35mm 	8PCS
E	SPRING WASHER 1/4"mm 	8PCS
F	FLAT WASHER 1/4" x 20mm 	8PCS
G	L KEY M4 	1PC

STEP 1 : ATTACH MIRROR SUPPORT (C) TO THE MIRROR BACK (A)
 AS STEP 1, THEN TIGHTEN WITH JCBC (D), Spring Washer (E) &
 FLAT WASHER (F) BY USING L KEY (G).
 MAKE SURE MARKING LINE OF SUPPORT MUST SAME LEVEL
 AS BOTTOM OF MIRROR BASE.

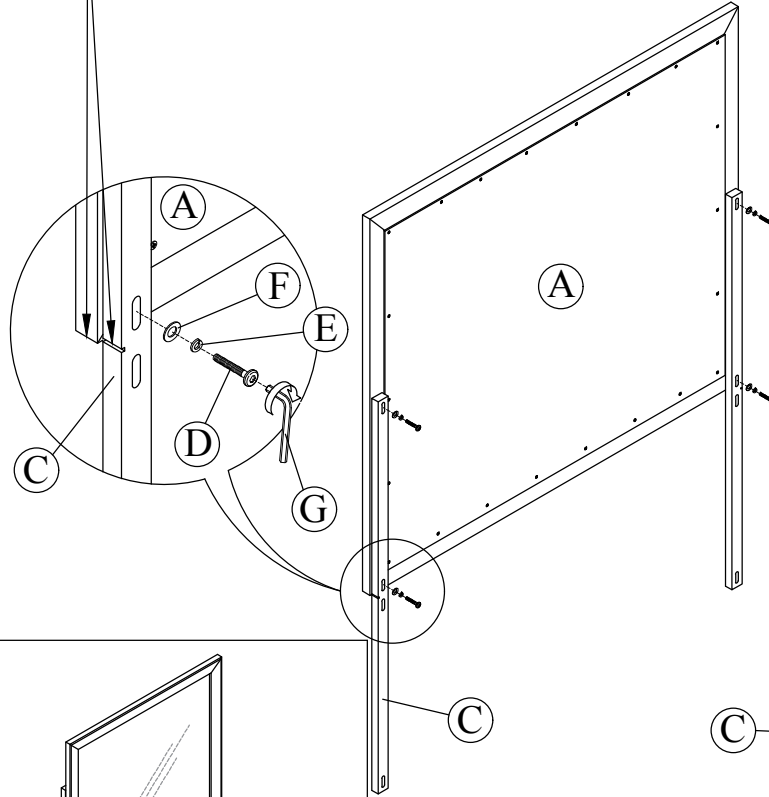

STEP 2 : PLACE THE MIRROR THAT WITH SUPPORT ON THE
 TOP OF DRESSER (B). THEN ALIGN CENTER.
 AS SHOWN AND TIGHTEN WITH JCBC (D), SPRING
 WASHER (E) & FLAT WASHER (F) BY USING
 L KEY (G).

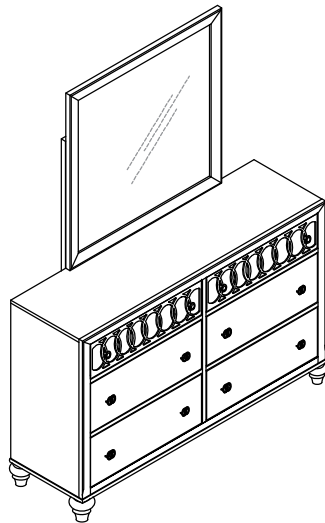

COMPLETED!

