

# ASSEMBLY INSTRUCTIONS

**MODEL : 0170B  
KING (4+8)**

**(Box 1)**  
BOX OF HEADBOARD & FOOTBOARD

No	ITEM	Qty
A	Headboard	1 pc
B	Footboard	1 pc
C	Headboard Leg (L/R)	2 pcs
D	Bed Slats	4 pcs
E	Bed Slats Support	8 pcs

**(Box 2)**  
BOX OF SIDE RAIL

No	ITEM	Qty
F	Side Rail	2 pcs

**(Box 1)**  
HARDWARE LIST

No	ITEM	Qty
1	Csk M4 x 32mm	8 pcs
2	JCBC M6 x 30mm	6 pcs
3	SPRING WASHER 1/4" Rbw	6 pcs
4	Flat Washer 1/4"ID x 13mmOD BK	6 pcs
5	ALLEN KEY m4x65mm Blk	1 pc
6	ALLEN KEY m5x65mm Blk	1 pc

**STEP 1 :** Attach Head Board Leg ( B ) to Head Board ( A ) as shown using JCBC BOLT ( 2 )with Spring Washer ( 3 ), Flat washer ( 4 ) and securing with ALLEN KEY ( 5 ).

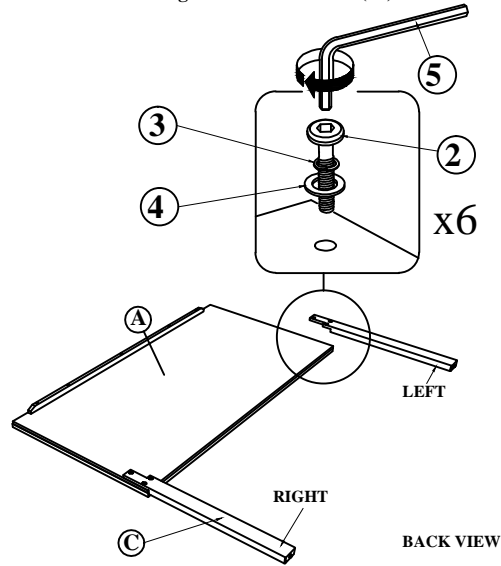

**STEP 2 :** Hook SIDE RAIL ( F ) TO HEAD BOARD ( A ) closely and push down to fit. repeat step 2 with other end of rail to hook onto FOOTBOARD ( B ).

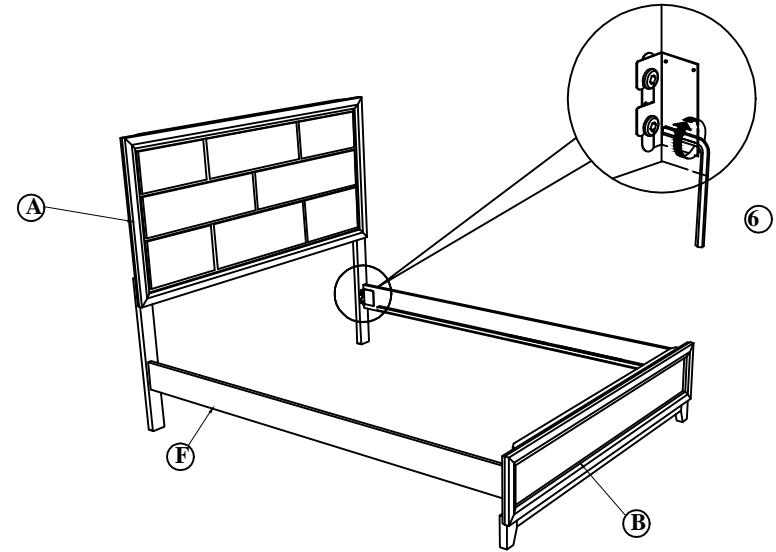

**STEP 3 :** Tighten the 4 Corner with Allen Key ( 6 ). Fix the Bed Slat Support Leg ( E ), to Bed Slat ( D ) as shown . Install the bed slat ( D ) to side rail ( F ) and tighten with Csk Screw ( 1 ) as per diagram shown. (NOTE: THE SETUP MUST DONE AT THE DECIDED LOCATION FOR THE BED TO OBTAIN PERFECT STABILITY)

**STEP 3.2 :**

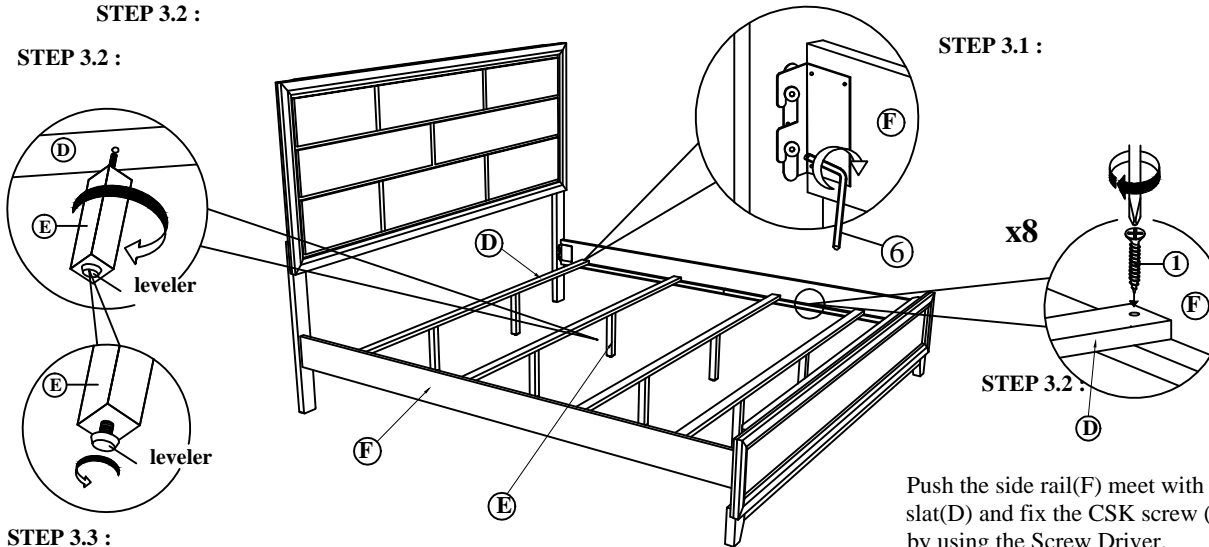

**STEP 3.3 :**

Push the side rail(F) meet with wooden slat(D) and fix the CSK screw (1) by using the Screw Driver.

**NOTE :** MUST TIGHTEN SCREWS PERIODCALLY WITH USE SCREW WILL BECOME LOOSE CHECK TIGHTNESS OF ALL SCREW EVERY 6-8 WEEKS.