

ASSEMBLY INSTRUCTIONS

MODEL : FBQHFR-058A + FBQSRR-019F
 REVISION : A

NO	PART & HARDWARE LIST IN HEADBOARD & FOOTBOARD	QTY.
A	HEADBOARD	1PC
B	LEG (Marking L & R)	2PCS
C	JCBC M6 X 30mm	6PCS
D	SPRING WASHER $\varnothing\frac{1}{4}$ "	6PCS
E	FLAT WASHER $\varnothing\frac{1}{4}$ " x 13mm	6PCS
F	L KEY M4	1PC
G	L KEY M5	1PC
H	FOOTBOARD	1PC
NO	PART & HARDWARE LIST IN SIDERAIL	QTY.
I	SIDERAIL	2PCS
J	SLATS	3PCS

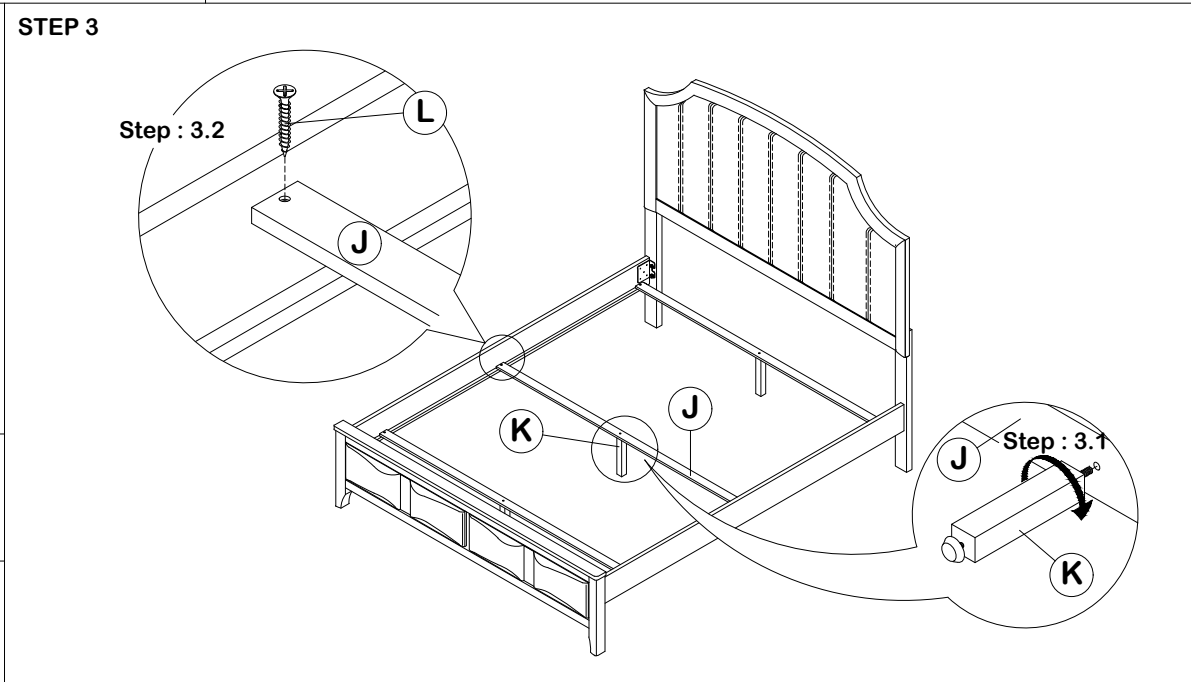
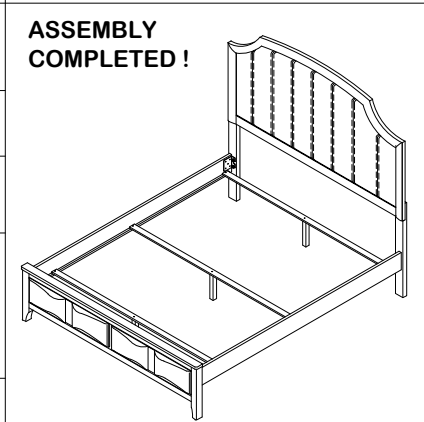
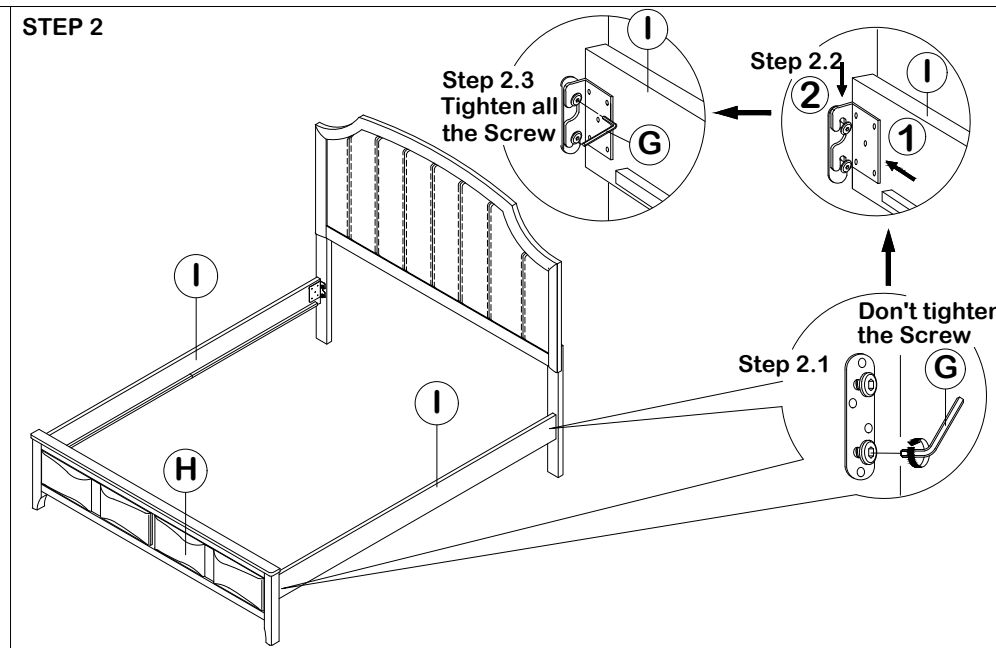
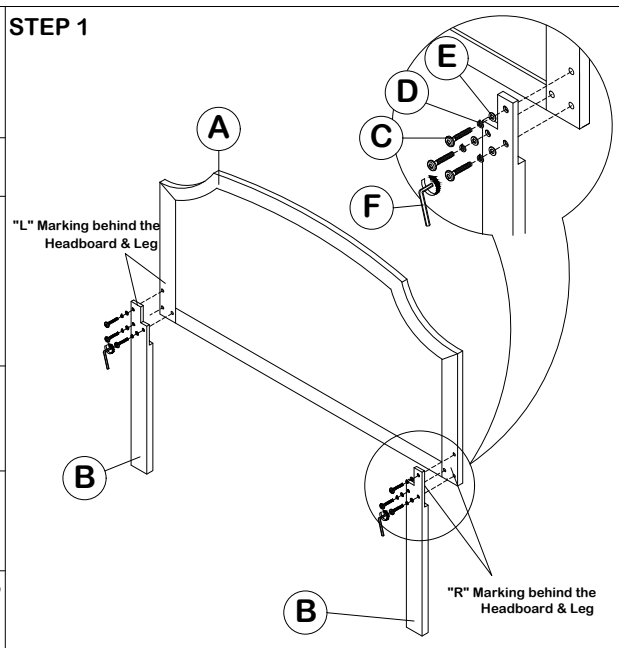

K	BED SLAT SUPPORT	3PCS
L	CSK M4 x 32mm	6PCS