

80" SYM Table

(224)



SEASIDE CASUAL

MADE IN RHODE ISLAND



ASSEMBLY INSTRUCTIONS

1

PLEASE READ INSTRUCTIONS COMPLETELY BEFORE BEGINNING.
Carefully remove contents from box. Make sure that all parts and hardware are included using the Parts List below.

Tools Required: 4mm Allen Wrench (included); #2 Phillips Head Screwdriver;

Leg Assemblies

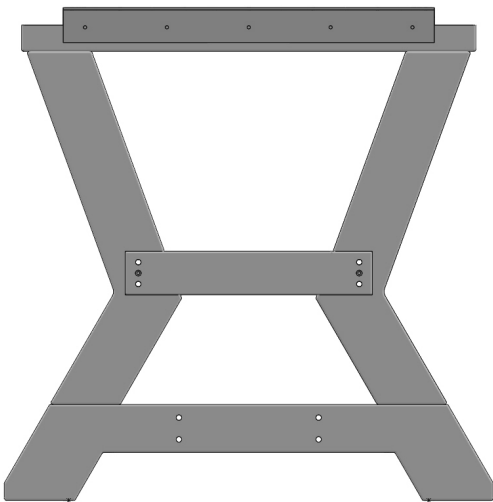

x 2

Table Top Assembly

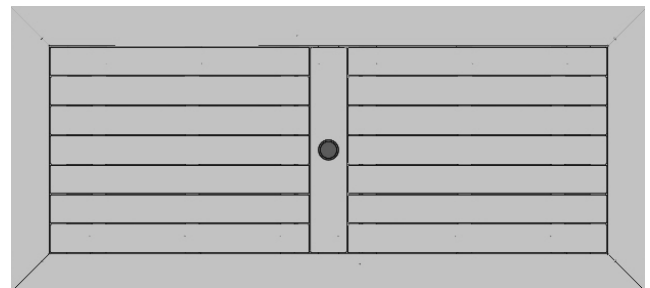

x 1

Stretchers



x 4

3/4" Phillips Pan Head Screw

Actual Size



Part Code: 316-8X3/4PPS

x 14

5/8" Bung

Actual Size



x 16

80mm Hex Lag

Actual Size

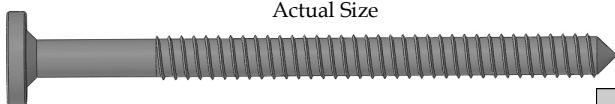

Part Code: 316-1/4-10-80HL

x 16

4mm Allen Wrench

Actual Size

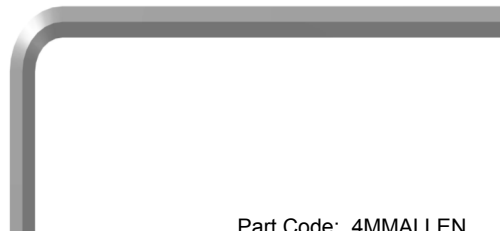

Part Code: 4MMALLEN

x 1

WARRANTY QUESTIONS OR COMMENTS PLEASE CALL TOLL FREE AT 1-800-809-3114

2

ATTACH STRETCHERS TO LEG ASSEMBLIES

Attach stretchers to leg assemblies using (16) 80 mm Hex Lags thru counter-bored holes in Leg Assembly into pilot holes in ends of Stretchers. Plug holes with 5/8" Bungs.

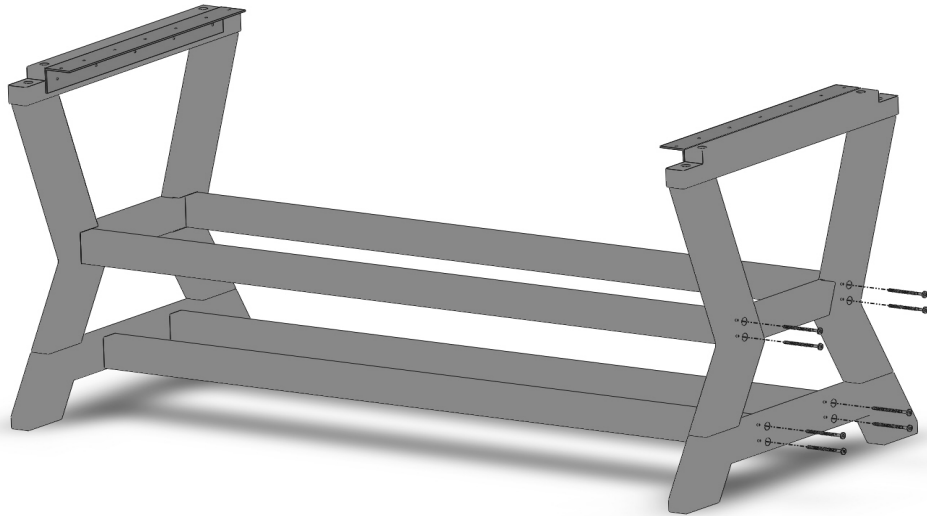

3

ATTACH BASE ASSEMBLY TO TABLE TOP

Turn Base upside down onto Table Top aligning legs in between outer aluminum table top cleats. Secure using (14) 3/4" Phillips Pan Head Screws.

